



Aras DevOps 1.5

User Guide

Document #: D-008576

Last Modified: 7/1/2024

Copyright Information

Copyright © 2024 Aras Corporation. All Rights Reserved.

Aras Corporation
100 Brickstone Square
Suite 100
Andover, MA 01810
Phone: 978-691-8900

E-mail: support@aras.com

Website: <https://www.aras.com/>

Notice of Rights

Copyright © 2024 by Aras Corporation and/or its affiliates. All rights reserved.

This document is protected by U.S. and international copyright laws and conventions. No copyright may be obscured or removed from this document. This document may not be modified or altered, or reproduced or transmitted in any form, without the explicit permission of the copyright holder.

Aras Innovator, Aras, and the Aras Corp "A" logo are registered trademarks of Aras Corporation in the United States and other countries.

All other trademarks referenced herein are the property of their respective owners.

Notice of Liability

THIS DOCUMENT IS PROVIDED FOR INFORMATIONAL PURPOSES ONLY, AND THE CONTENTS HEREOF ARE SUBJECT TO CHANGE WITHOUT NOTICE. THE INFORMATION CONTAINED IN THIS DOCUMENT IS DISTRIBUTED ON AN "AS IS" BASIS, WITHOUT WARRANTY OF ANY KIND, EXPRESS OR IMPLIED, INCLUDING, BUT NOT LIMITED TO, THE IMPLIED WARRANTIES OF MERCHANTABILITY AND FITNESS FOR A PARTICULAR PURPOSE OR A WARRANTY OF NON-INFRINGEMENT. ARAS SHALL HAVE NO LIABILITY TO ANY PERSON OR ENTITY WITH RESPECT TO ANY LOSS OR DAMAGE CAUSED OR ALLEGED TO BE CAUSED DIRECTLY OR INDIRECTLY BY THE INFORMATION CONTAINED IN THIS DOCUMENT OR BY THE SOFTWARE OR HARDWARE PRODUCTS DESCRIBED HEREIN.

Table of Contents

Send Us Your Comments	7
1 Introduction	8
1.1 Purpose	8
1.2 Scope	8
1.3 Target Audience	8
2 Aras DevOps Overview	9
2.1 Overview	9
2.2 Centralized Development Model vs. Distributed Development Model (Aras DevOps).....	9
3 Customization.....	11
3.1 Standard Development Environment (SDE)	11
3.1.1 SDE Overview	11
3.1.2 Azure DevOps SignOn	12
3.1.3 SDE Navigation	13
3.2 Local Development Environment (LDE).....	20
3.2.1 Connecting LDE to SDE	21
3.2.2 Obtaining Initial Baseline	22
3.2.3 Create Fork and Clone Repository	25
3.2.4 Review Working Directory	27
3.2.5 Local Environment Variables Set Up.....	28
3.2.6 Build and Deploy Locally	30
3.3 Continuous Integration and Continuous Delivery (CI/CD)	31
3.4 Testing.....	32
4 Contributor Process.....	33
4.1 The Contribution Process Overview.....	33
4.2 Adding Remote Reference	34
4.3 Making Changes in Local Repo	35
4.4 Add or Modify file in Code Tree.....	36
4.5 Exporting Packages	37
4.5.1 Make Required Changes in Aras Innovator Instance.....	37
4.5.2 Export Package After the Changes	37
4.6 Copying the Export Utility's Output to the Local Repo	38
4.7 Staging Modified Files	38
4.8 Continuous Integration Script.....	39
4.9 Test the Deployment Locally	39
4.10 Pushing Changes to Fork.....	40
4.10.1 Fetching Changes/Rebasing	40
4.10.2 Pushing Changes to Fork	41
4.11 Creating a Pull Request	41
4.12 Trigger, Build and Test.....	43

4.13	Reviewing a Pull Request	43
4.14	Merging the Pull Request.....	45
5	Preparing the Project's Initial Baseline	48
6	Baseline Management.....	49
7	Pipelines	50
7.1	Deploy to System Integration Testing (SIT) Environment.....	50
7.2	Generate New Baseline	52
7.2.1	<i>Creating Tag on Last Approved Commit.....</i>	<i>52</i>
7.2.2	<i>Running the Baseline Pipeline</i>	<i>53</i>
7.3	Delete Aras Innovator from SIT Environment	55
7.4	Delta deployment to production and non-production environments	59
7.4.1	<i>Redeploy UAT deployment on Existing Database</i>	<i>59</i>
8	Using Transformations	65
8.1	Transformation Overview	65
8.2	Type of Transformation	65
8.3	The Purpose of Transformation	65
8.4	Utilizing Transformation	66
8.4.1	<i>Example 1: XML Document Transformation (XDT).....</i>	<i>66</i>
8.4.2	<i>Example 2: JSON Document Transformation (JDT)</i>	<i>67</i>
8.5	Ignore Configuration Files Transformation.....	67
8.6	Environment Specific configuration.....	68
8.6.1	<i>Example: Define an environment specific login screen.....</i>	<i>68</i>
8.6.2	<i>Default variable groups.....</i>	<i>73</i>
8.6.3	<i>Adding a secret.....</i>	<i>73</i>
8.6.4	<i>Variables naming and scope</i>	<i>73</i>
8.6.5	<i>Restrictions.....</i>	<i>74</i>
9	External authentication.....	75
9.1	Aras Innovator External Authentication using SAML 2.0 Authentication	75
9.1.1	<i>Example: Setup of Aras Innovator SAML 2.0 Authentication with Azure as Identity provider</i>	<i>76</i>
9.2	Configuring Secure Files.....	83
9.2.1	<i>Upload a certificate as a secure file</i>	<i>83</i>
9.2.2	<i>Configure File Permissions for Pipeline</i>	<i>84</i>
9.2.3	<i>Add a Transformation with Link to Certificate.....</i>	<i>87</i>
9.3	SAML2 Authentication Plugin Configuration	89
9.3.1	<i>Base Configuration</i>	<i>89</i>
9.3.2	<i>Configuring Identity Provider Metadata</i>	<i>90</i>
9.3.3	<i>Configuring Service Provider Metadata.....</i>	<i>92</i>
9.3.4	<i>Configuring Certificates</i>	<i>95</i>
9.3.5	<i>Additional Authentication Options Configuration.....</i>	<i>97</i>
9.3.6	<i>Aras Innovator User Setup</i>	<i>98</i>
9.4	Generic User Mapper	100

9.4.1	GenericUserMapper Plugin Configuration.....	100
10	Packaging	106
10.1	Summary of Modeling	106
10.2	Review of Packaging Scenarios.....	107
10.2.1	Case 1	107
10.2.2	Case 2	108
10.2.3	Case 3	108
10.3	Packaging Tools and Methods.....	109
10.4	Create and Manage New Application	110
10.4.1	Creating a Package Definition.....	110
10.4.2	Export Package and Update the Imports Manifest File.....	112
10.4.3	Confirming Manifest Changes in Version Control System	112
11	Update Repository to Use Single Package	113
12	Change Management and Implementation.....	116
12.1	Production Countdown Sequence	116
13	Branding Customization.....	119
13.1	Splash Screen.....	119
13.2	Change Banner	121
	Appendix I: Local Development Environment Setup	123
	Installing Windows Powershell	123
	Installing Chocolatey using Windows PowerShell.....	123
	Installing Git.....	124
	Installing Azure CLI	125
	Required Specifications.....	125
	Appendix II: Standard Solution Packaging Tools.....	126
	Export.exe.....	126
	Import.exe.....	126
	Consoleupgrade.exe	126
	Appendix III: Adding Applications to a Project.....	127
	Appendix IV: Using a Shared Repository and Merging Conflicts	128
	Use Shared Repository	128
	Connect to Shared Repository	128
	Push Changes to Shared Repository	128
	Fetch Changes from Shared Repository	128
	Managing File Conflicts	128
	Resolving Merged Conflicts.....	129
	Sharing Changes with the Remote Repository	129
	Using Stash	130
	Appendix V: Transformations	131
	Appendix VI: Vault Replication	135
	Create Transformation File.....	135
	Run Pipelines.....	135

Send Us Your Comments

Aras Corporation welcomes your comments and suggestions on the quality and usefulness of this document. Your input is an important part of the information used for future revisions.

- Did you find any errors?
- Is the information clearly presented?
- Do you need more information? If so, where and what level of detail?
- Are the examples correct? Do you need more examples?
- What features did you like most?

If you find any errors or have any other suggestions for improvement, indicate the document title, and the chapter, section, and page number (if available).

You can send comments to us in the following ways:

Email:

TechDocs@aras.com

Subject: Aras Product Documentation

Or,

Postal service:

Aras Corporation

100 Brickstone Square

Suite 100

Andover, MA 01810

Attention: Aras Technical Documentation

If you would like a reply, provide your name, email address, address, and telephone number.

If you have usage issues with the software, visit <https://www.aras.com/support/>

1 Introduction

1.1 Purpose

This user guide provides detailed information for contributors utilizing the Aras DevOps service to manage and customize their locally deployed Aras Innovator and application instances.

1.2 Scope

The scope of this user guide provides instructions to define, manage, customize, and validate locally deployed customizations, as well as outline the following:

- Contributor Process
- Branding
- Baselines
- Pipelines
- Transformations
- Packaging
- Change Management and Implementation
- Appendices which provide tool information and instructions

This user guide provides good practices to ensure proper configuration management of a solution for business-critical operations.

Experience with these processes and procedures will determine what tools contributors already use and prefer. The tools mentioned in this user guide are a suggestion for consistency and practical embodiment of the concepts, not as endorsements or mandates.

1.3 Target Audience

This document is intended for contributors who are responsible for performing the instructions outlined in this document (customizers, PLM developers and stakeholders involved in software development and project management.)

It is the responsibility of contributors working on the implementation of solutions using the Aras Innovator platform to adhere to the provided information and steps outlined in this user guide.

2 Aras DevOps Overview

2.1 Overview

Aras DevOps is a subscription service that provides a cloud-based set of tools, scripts, and processes to manage Aras Innovator customizations for an Aras Innovator implementation project.

Aras DevOps is inherently part of the Aras Enterprise subscription (SaaS) but can also be purchased separately as an Aras DevOps subscription to support customer-hosted Aras Innovator environments.

2.2 Centralized Development Model vs. Distributed Development Model (Aras DevOps)

In the Centralized Development Model, developers collaborate and implement changes within shared installations of Aras Innovator, such as development, testing, and production instances. Developers export and import packages between the deployments and keep track of changes.

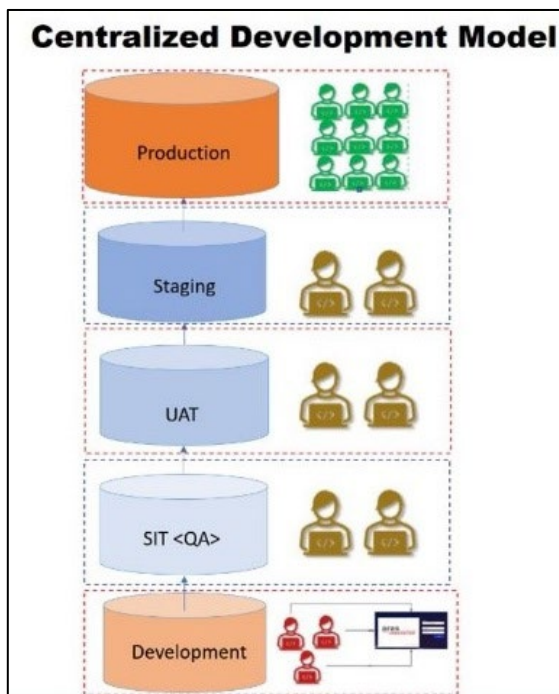

Aras DevOps enables developers to build and deploy an individual instance of Aras Innovator with a Distributed Development Model. Git (version control system) is used to modify the system, export, and store changes.

Modifications are extracted from Git to build the system. Aras DevOps is equipped to execute automated tests, written by the development team, specifically designed for the Aras Test Automation Framework (TAF) to verify the system's validity.

Multiple developers can contribute to the system, and Aras DevOps enables developers to identify conflicts and merge all their contributions into a single build. This enables early detection and resolution of conflicts, resulting in improved collaboration and development efficiency.

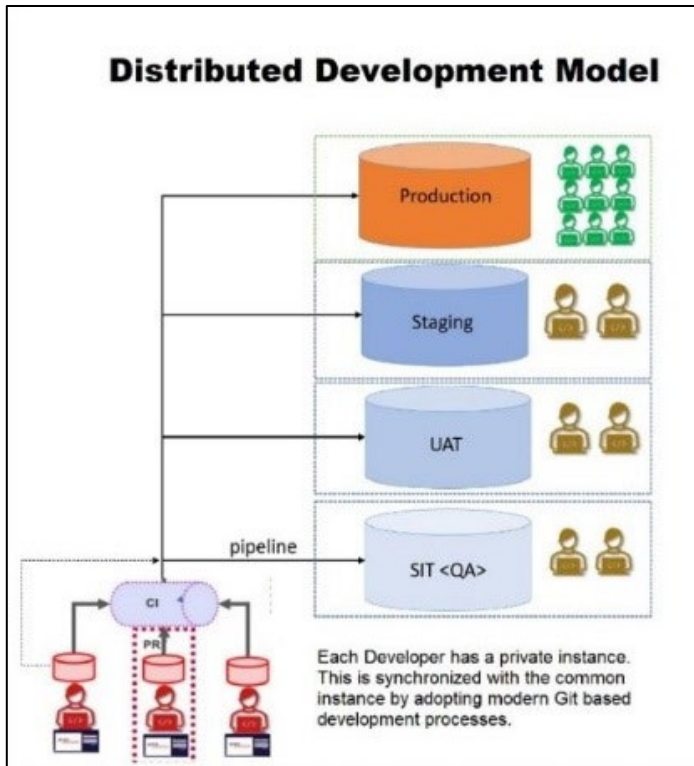

Note: The link to the production environment is not included for On-Premises customers who purchased Aras DevOps as a stand-alone service. This link is included for Aras Enterprise subscription customers.

3 Customization

System customization consists of configurations per customer usability. The following outlines the general contributor configurations/customizations:

- Workflow
- Reporting
- Interfacing
- Configuring lifecycles and other preferences
- Enhancing
- Forms

Contributors must set up a Local Development Environment (LDE) for local project configuration and access to the Standard Development Environment (SDE) for contributions.

3.1 Standard Development Environment (SDE)

3.1.1 SDE Overview

The Standard Development Environment (SDE) is included in the Aras DevOps offering which enables contributors to streamline their customized Aras solution in a cloud environment. It consists of the SIT and Build environment as outlined in this section.

SDE consists of tools and procedures that support contributors in implementing standard Continuous Integration/Continuous Deployment (CI/CD) practices. This environment is specially designed to streamline the software development process by facilitating efficient collaboration, version control, code testing, and seamless deployment.

The following tools are provided by Aras:

- Aras Visual Studio Plugin: Allows for seamless integration between Aras and Visual Studio.
- Import/Export: Tools that facilitate the easy movement of data in and out of the system.
- Test Automation Framework (TAF): Helps in validating the functionality of the system.

To supplement these resources, the SDE uses Azure DevOps services, which provides a development environment where contributors can commit their changes, build the applications, and test the Aras customizations. This ensures a standardized, repeatable process, reducing the risk of deployment errors.

The SDE incorporates Aras Pipelines, which are workflows that automate steps in the software delivery process, such as build, test, and deployment. By integrating these different components, the SDE provides a comprehensive suite of tools for managing the entire software development lifecycle.

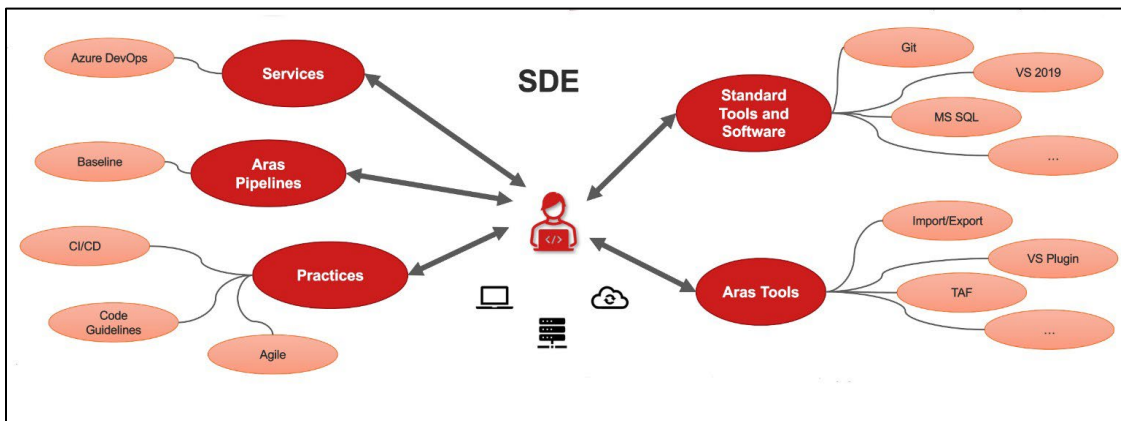

Once access is granted by Aras, a link to the SDE implementation project is emailed to the requester (e.g. <https://dev.azure.com/{organization}/{project}>.) This link navigates to the dedicated space within Aras DevOps. All developers should have access to this link.

The Azure DevOps environment is only available to customers who have acquired either the Aras DevOps Subscription or the Aras Enterprise Subscription.

The local development environment configuration includes developer machine requirements which is comprised of creating a Fork, Baseline setup, Aras repository clone, and environment setup.

Refer to the Appendices at the end of this user guide for instructions related to tools suggested by Aras.

3.1.2 Azure DevOps SignOn

The following steps outline the process of signing into Azure DevOps:

1. Click the <https://dev.azure.com/{organization}/{project}> link.
2. Enter the registered email address used for access.
3. Install the **Microsoft Authenticator** application on a mobile device.
4. Click **Next** on the Microsoft Authenticator dialog box.

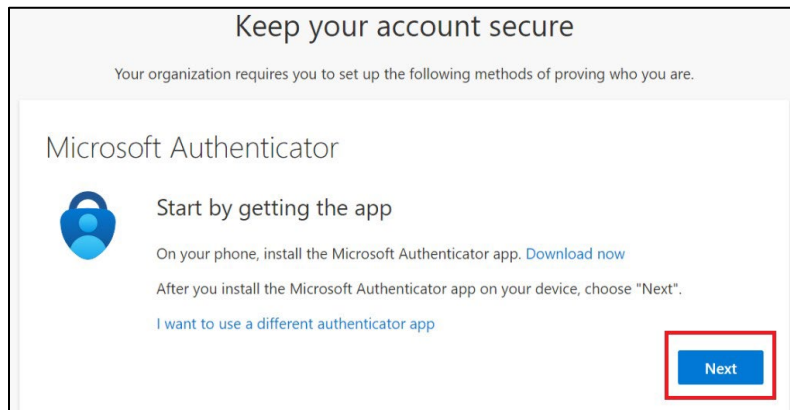

5. Open the **Microsoft Authenticator** application on the mobile device and click the (+) icon.
6. Select the account and scan the QR code that appears on the computer.
7. Click **Next**.

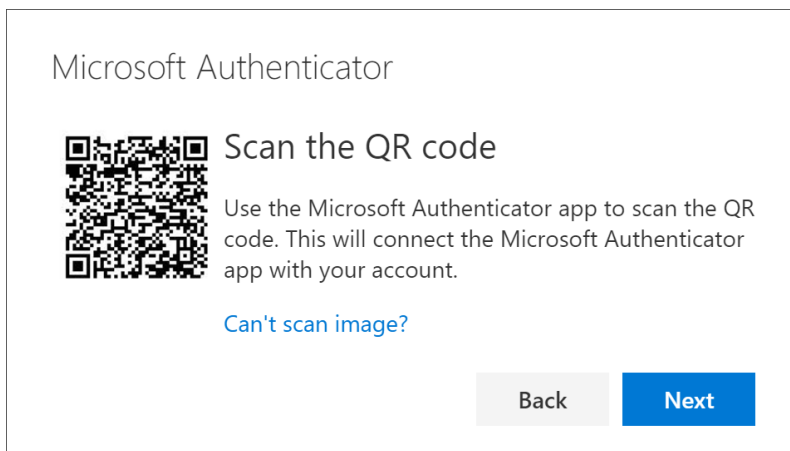

3.1.3 SDE Navigation

The URL to the SDE environment is accessible only after completion of the invitation process that requires to set up multi-factor authentication.

When connecting to the SDE URL, the following screens appear:

- **Azure DevOps landing page:** The implementation project that is visible represents the area where the project team customizes Aras Innovator for the subscriber.

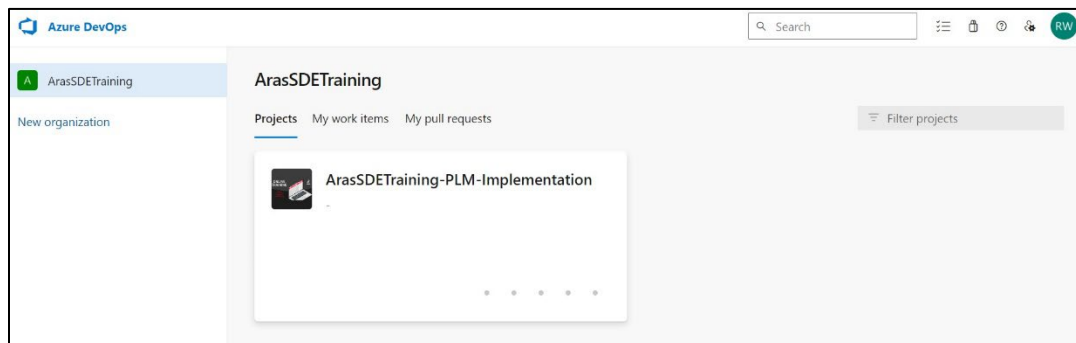

- **Azure DevOps Structure:** Displays required information.

Azure DevOps Structure

- Overview – dashboards (scrum Masters)
- Boards – backlog, queries, etc.
- Repos – team vs. Individual
- Pipelines – ContinuousIntegration, DeployToSIT, etc.
- Test Plans – Test Plans, Runs
- Artifacts – Baselines, Feeds

- **Dashboards:** Scrum masters use these to track project progress for team members' view. A link is provided for traceability between change management and implementation.

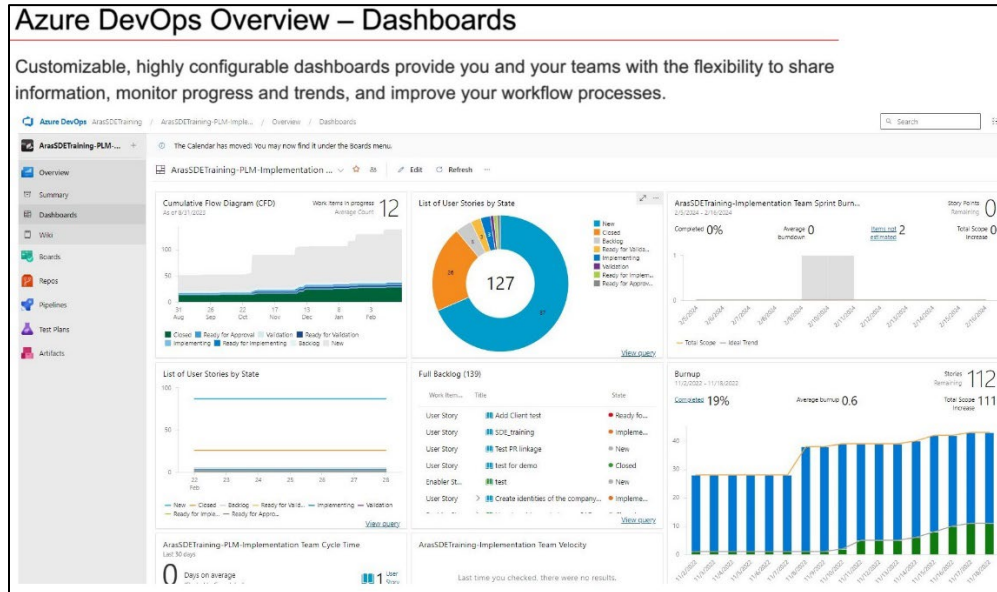

- **Analytics Views and Wiki Page:** The team project wiki serves as a platform for sharing information with other team members. Provisioning a wiki from scratch initiates a new Git repository that stores Markdown files, images, attachments, and a sequence of pages. The wiki has the capability to support collaborative editing of both its content and structure. Aras uses the wiki to share the URLs of SIT test instances.

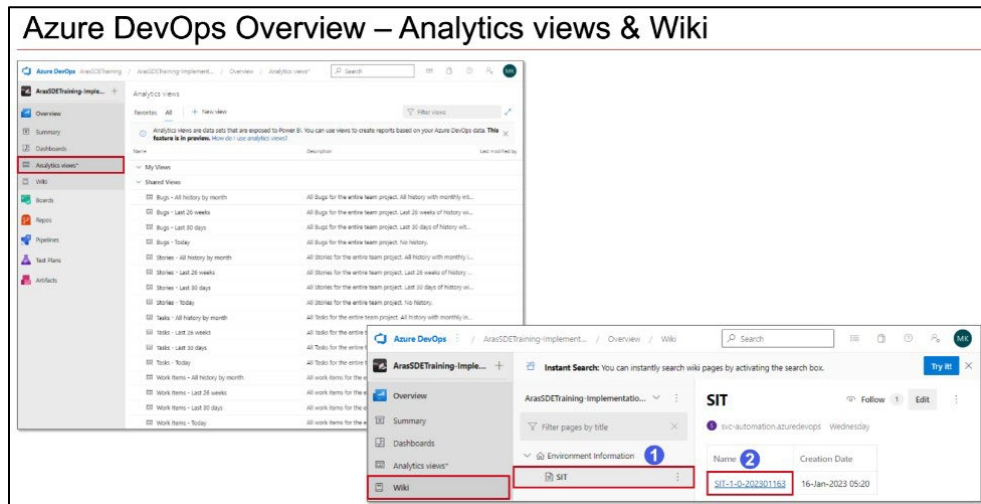

- **Work Items:** These items are required for approved changes. This may encompass other tasks necessitated by the project or the tracking of requests made to Aras.

Azure DevOps Boards – Work Items

- Work item types (WITs) represent the core of the Azure DevOps tracking system and can be a bug, a requirement, a general to-do, etc.
- Each work item has a unique ID to keep track of its references from its creation to its implementation as a piece of executable software.

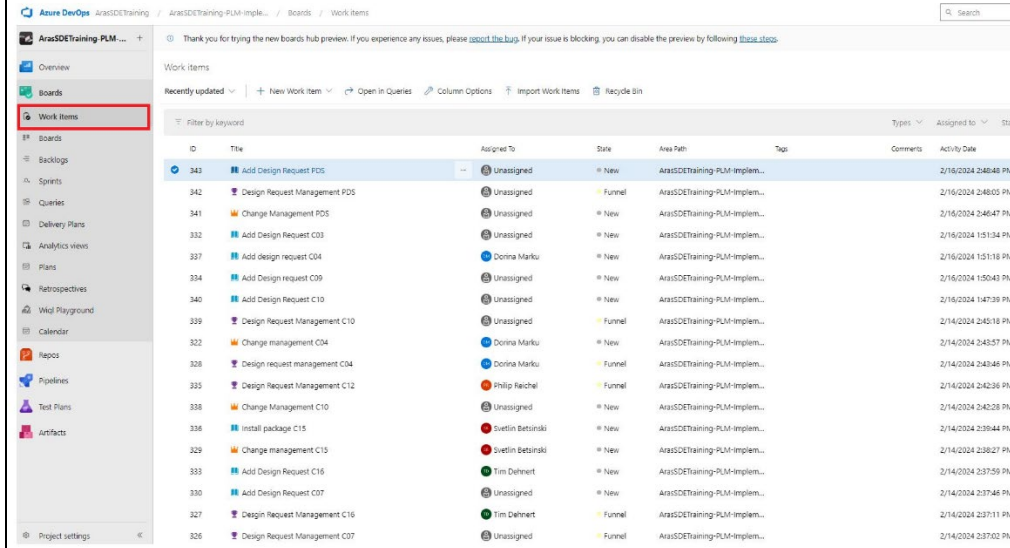

ID	Title	Assigned To	Date	Area Path	Type	Comments	Activity Date
343	Add Design Request P05	Unassigned	New	ArasDevTraining-PLM-implem...	New		2/16/2024 2:40:48 PM
342	Design Request Management P05	Unassigned	Funnel	ArasDevTraining-PLM-implem...	Funnel		2/16/2024 2:46:47 PM
341	Change Management P05	Unassigned	New	ArasDevTraining-PLM-implem...	New		2/16/2024 1:51:34 PM
332	Add Design Request C03	Unassigned	New	ArasDevTraining-PLM-implem...	New		2/16/2024 1:51:34 PM
337	Add design request C04	Donna Marku	New	ArasDevTraining-PLM-implem...	New		2/16/2024 1:51:38 PM
334	Add Design request C09	Unassigned	New	ArasDevTraining-PLM-implem...	New		2/16/2024 1:50:43 PM
340	Add Design Request C10	Unassigned	New	ArasDevTraining-PLM-implem...	New		2/16/2024 1:47:39 PM
339	Design Request Management C10	Unassigned	Funnel	ArasDevTraining-PLM-implem...	Funnel		2/14/2024 2:45:18 PM
322	Change management C04	Donna Marku	New	ArasDevTraining-PLM-implem...	New		2/14/2024 2:43:57 PM
328	Design request management C04	Donna Marku	Funnel	ArasDevTraining-PLM-implem...	Funnel		2/14/2024 2:43:46 PM
335	Design Request Management C12	Philip Rachel	Funnel	ArasDevTraining-PLM-implem...	Funnel		2/14/2024 2:42:36 PM
338	Change Management C10	Unassigned	New	ArasDevTraining-PLM-implem...	New		2/14/2024 2:42:28 PM
336	Install package C15	Svetlin Betinski	New	ArasDevTraining-PLM-implem...	New		2/14/2024 2:39:44 PM
329	Change management C10	Svetlin Betinski	New	ArasDevTraining-PLM-implem...	New		2/14/2024 2:38:27 PM
333	Add Design Request C16	Tim Dehnert	New	ArasDevTraining-PLM-implem...	New		2/14/2024 2:37:59 PM
330	Add Design Request C07	Unassigned	New	ArasDevTraining-PLM-implem...	New		2/14/2024 2:37:46 PM
327	Design Request Management C16	Tim Dehnert	Funnel	ArasDevTraining-PLM-implem...	Funnel		2/14/2024 2:37:11 PM
326	Design Request Management C07	Unassigned	Funnel	ArasDevTraining-PLM-implem...	Funnel		2/14/2024 2:37:02 PM

- **Work Item Structure:** Azure DevOps manages the process by the type of definition set by Aras Global Cloud Services (GCS). GCS continually updates the process to address Subscriber input/feedback. The current Agile Solution Delivery version is 4.1.

Azure DevOps Boards – Agile Process Model

- Supports Agile planning methods, including Scrum, and tracks development and test activities separately. This process works great if you want to track user stories and (optionally) bugs on the Kanban board, or track bugs and tasks on the taskboard. The process type is based on **Agile Solution Delivery v3**, and this dictate the WITs used.
- Hierarchy
 - Epics
 - Features
 - Stories: User Story and Enabler Story, with Acceptance Criteria
 - Areas: Functional, capability attached/assigned to teams
 - Sprints (Iterations): Used for refinement /grooming
- Set definitions of Ready and Done
- Epics and features reflect the business focus, user stories and tasks are related to the development
- Example:
 - Area: Certification
 - Epic: Change Management
 - Feature: Design Request Management
 - User Story: Add Design Request

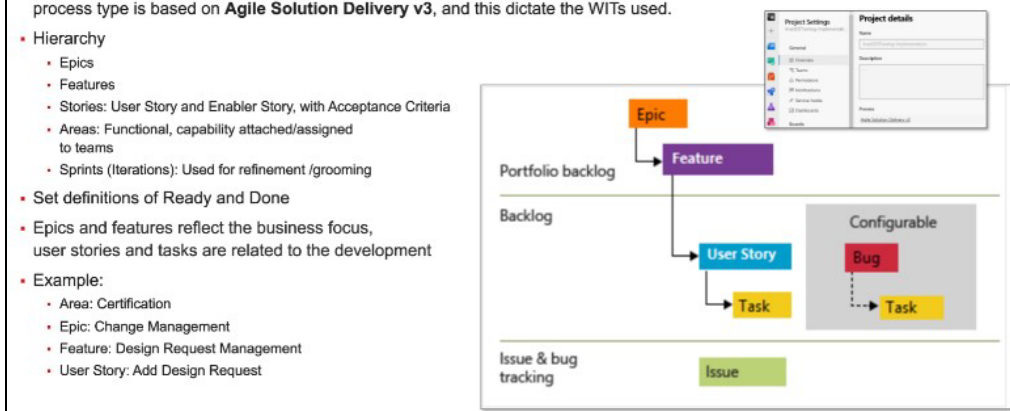

- **Boards:** The boards can be used to track a variety of work items, including features, user stories, tasks, bugs, and more. They support both Scrum and Kanban methodologies. Additionally, the boards include capabilities for planning sprints and managing backlogs, as well as generating reports on work progress.

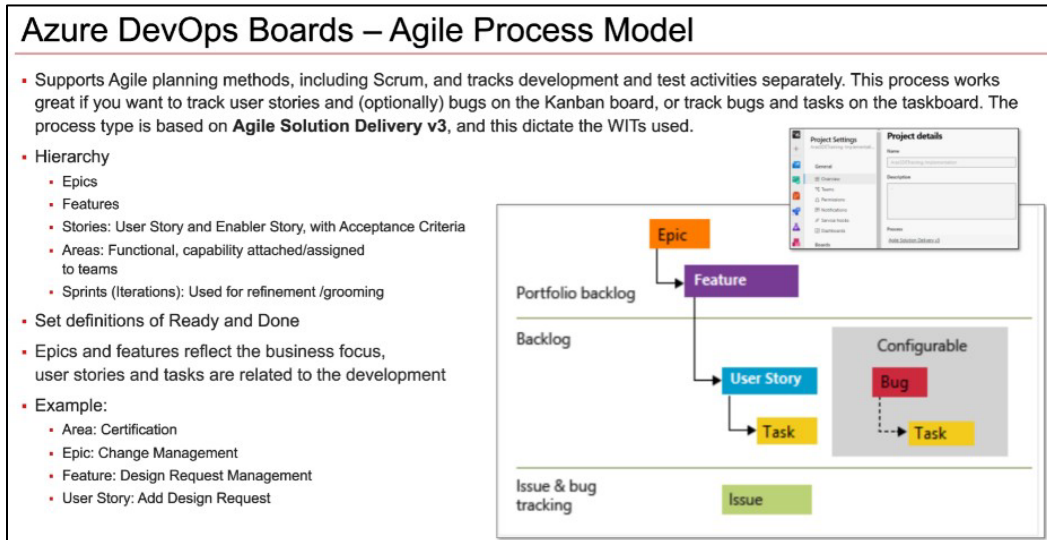

- **Backlogs:** Backlogs in Azure DevOps are used to manage and prioritize work items in a queue. They provide an ordered list of work items such as user stories, features, or bugs that the team needs to work on.

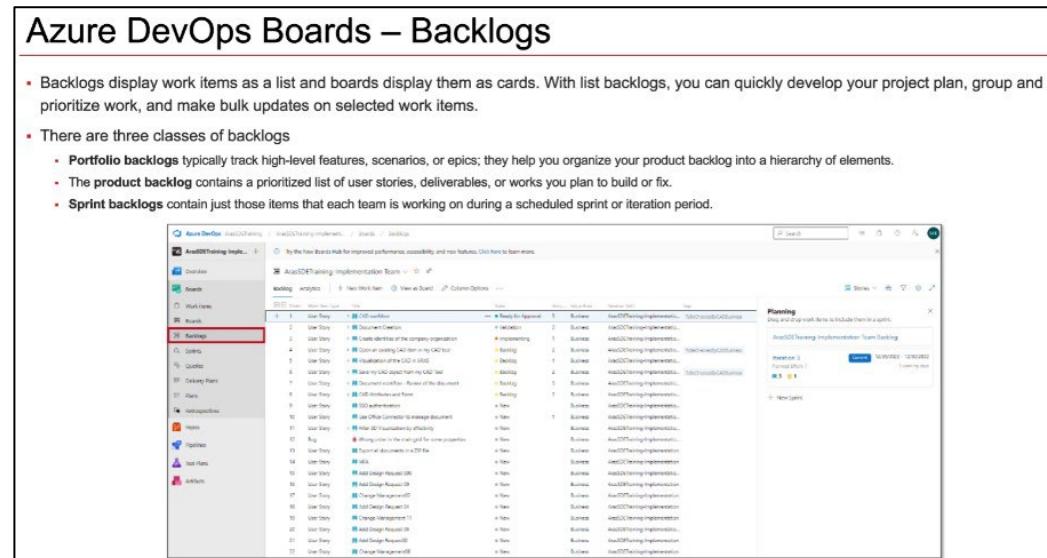

- **Sprints:** Sprints in Azure DevOps represent time-boxed iterations where a set amount of work is completed.

Azure DevOps Boards – Sprints

- Sprints, specified by Iteration Paths, are defined for a project and then selected by teams. A sprint cadence can vary between one week to four weeks or longer.
 - You assign work to sprints that teams commit to deliver at the end of the sprint.
 - Azure Boards tools rely on sprint assignments to a team Sprint backlogs, Taskboard, and Delivery plans.

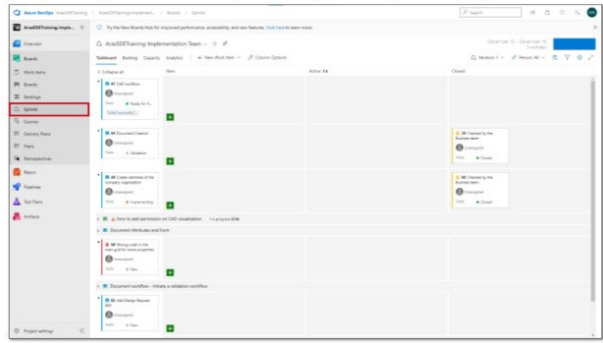

- **Queries:** Queries enable users to filter work items within or across projects for listing, updating, or sharing work items.

Azure DevOps Boards – Queries

- Queries enable you to filter work items within or across projects for the purposes of listing, updating, or sharing work items.

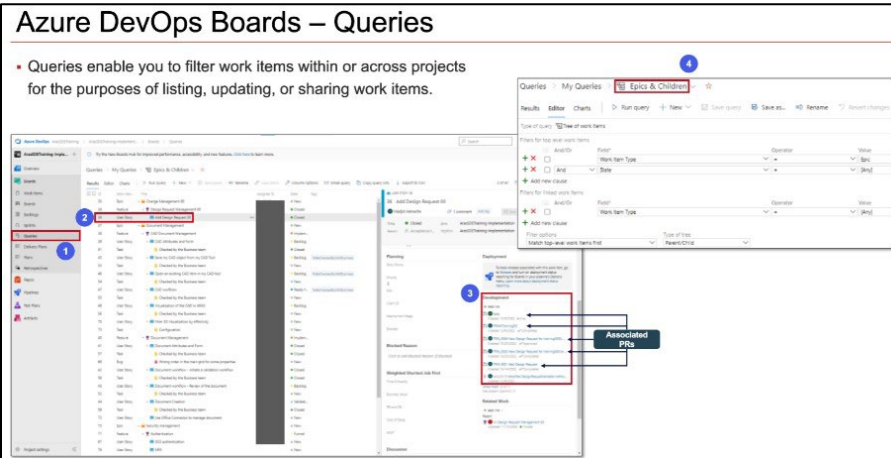

- **Repos:** There is only one main configuration repo per project for the Standard Development Environment. Notice the orange and white backgrounds of the Git logo. The white background repositories are Forks.

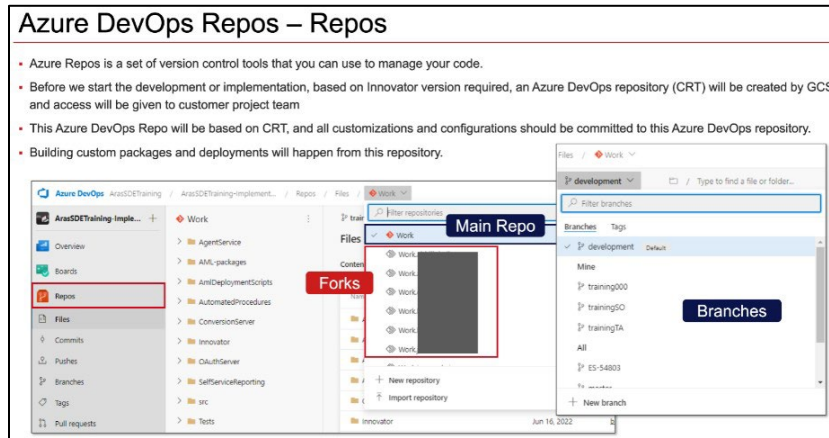

- **Files, Commits and Pushes:** In Azure DevOps, Files are the individual project components, Commits are snapshots of changes made to those files, and Pushes are the action of uploading these commits to a remote repository for team access and collaboration.

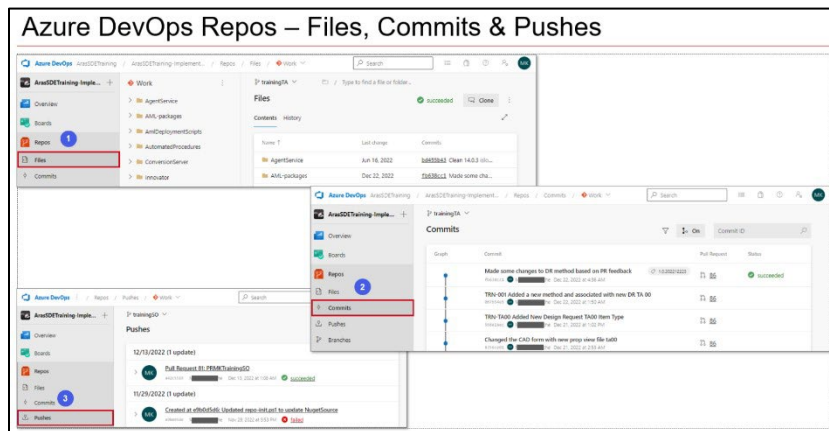

- **Branches, Tags and Pull Request:** In Azure DevOps, Branches are separate versions of the codebase for isolated development, Tags are reference points to specific versions of the code, and a Pull Request is a mechanism for developers to propose, review, and merge changes from one branch to another.

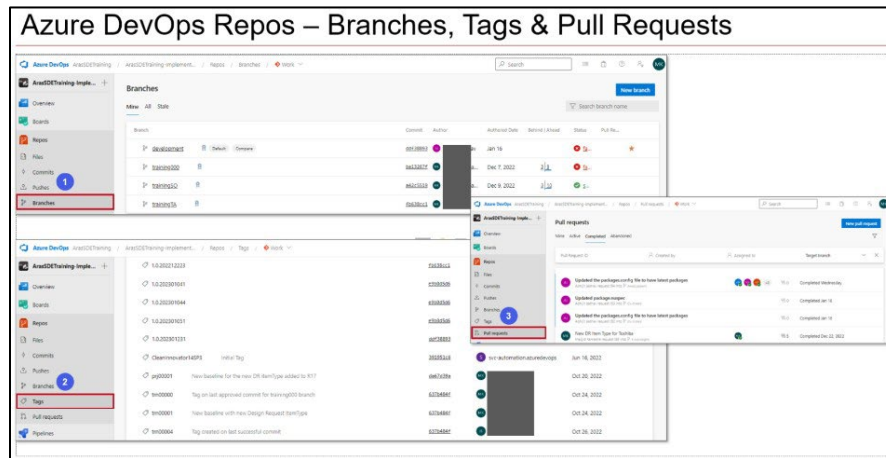

- **Pipelines:** Pipelines in Azure DevOps are automated workflows for continuous integration and delivery, enabling code build, test, and deployment processes.

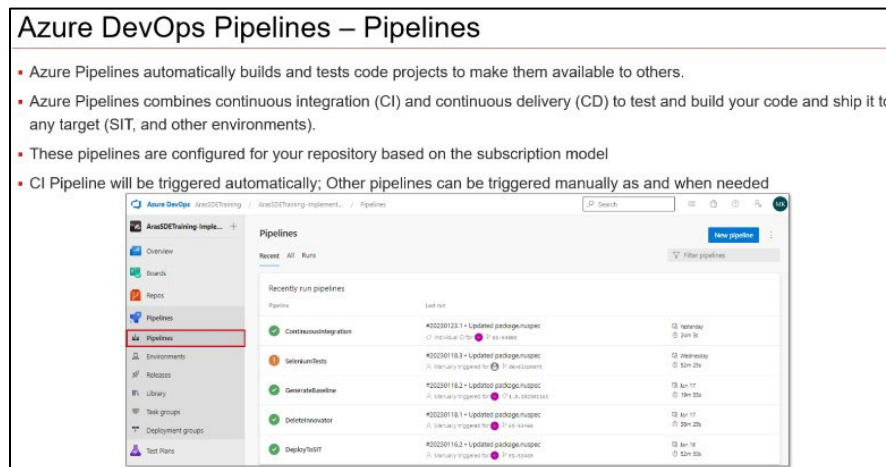

- **Test Plans:** Test Plans in Azure DevOps provide a structured approach for defining, tracking, and managing testing activities to ensure software quality.

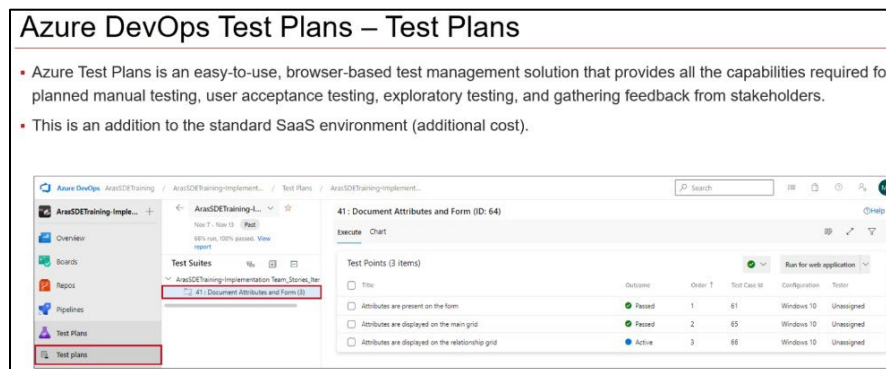

- **Progress Reports and Runs:** Progress Reports in Azure DevOps provide insights into the development lifecycle and project milestones, while Runs represent individual executions of tests, builds, or deployments.

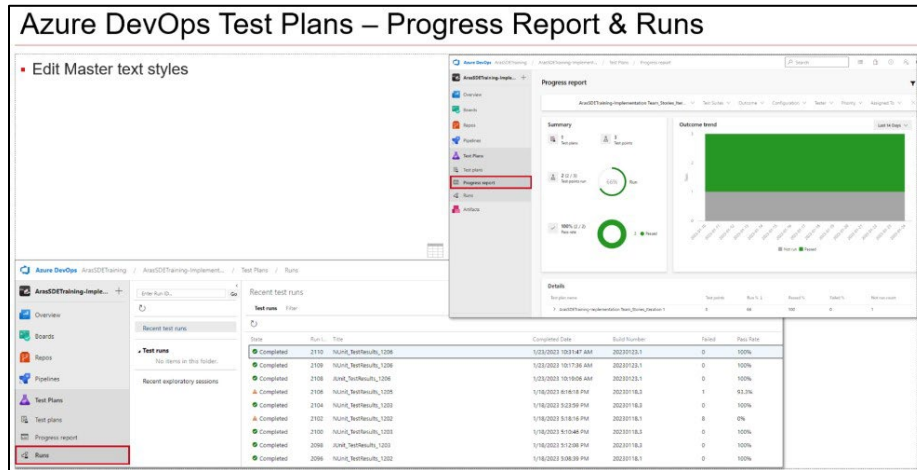

- **Baselines and Artifacts:** Baselines in Azure DevOps represent specific versions of the project for comparison or recovery, while Artifacts are the output files generated from build and release pipelines.

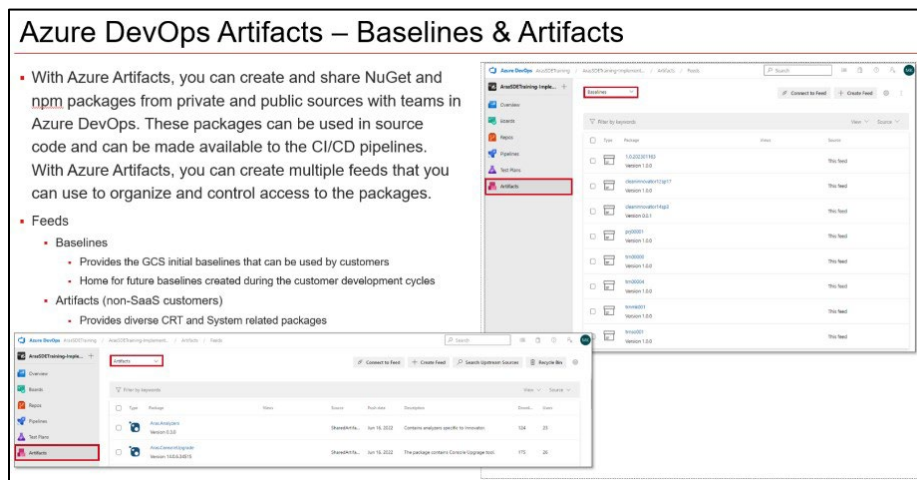

3.2 Local Development Environment (LDE)

A local development environment (LDE) is a configuration of software and tools set up on a developer's personal computer/laptop which enables developers to write, debug, and test software. This environment often mimics the production setting as closely as possible, encompassing programming languages, code editors, version control systems, and possibly virtual machines or containers. The LDE provides a space for developers to make and test changes without affecting the live application or production data.

Depending on company policies, an IT department may need to perform the below steps for users. Refer to Appendix I: Setting Up Local Development Environment for more details.

3.2.1 Connecting LDE to SDE

When working in the LDE, open **Windows PowerShell** as an administrator to connect to SDE. The following steps outline the process for connecting to a SDE:

1. Run **Windows PowerShell** as an administrator.

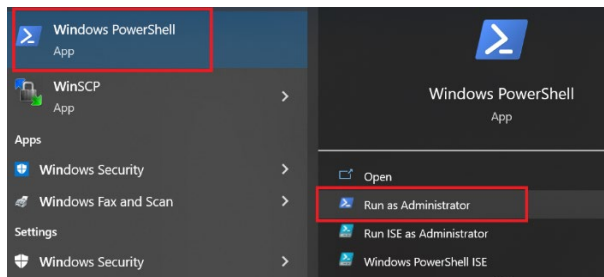

2. Execute command: **az login** (if tenant level access is missing execute command: **az login --allow-no-subscriptions**)

The Microsoft Azure dialogue box appears.



3. Select the **Microsoft Azure** account to launch Azure. The following message should appear:

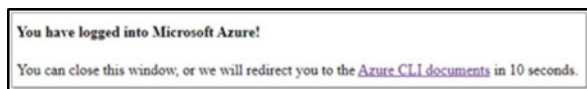

The utilization of **az login** might not consistently grant access to the specific SDE. If the **az login** does not work, use of the **Personal Access Token (PAT)** method is recommended.

With the LDE successfully linked to the SDE, the current baseline can now be obtained and stored.

3.2.2 Obtaining Initial Baseline

Aras uses a baseline as a database and code tree backup. When the project starts, Aras initializes the SDE with the current release of Aras Innovator and provides the corresponding baseline in the Baseline feeds in the artifacts.

Projects periodically generate new baselines and may create one at the start of a project to add applications and language packs.

The following steps outline the process to obtain the initial baseline:

1. Create a folder to save the baseline in the local machine. For example:
C:\ArasProjects\Baselines\Cleaninnovatorxxxspyy.
2. From **Azure DevOps**, select **Artifacts**.

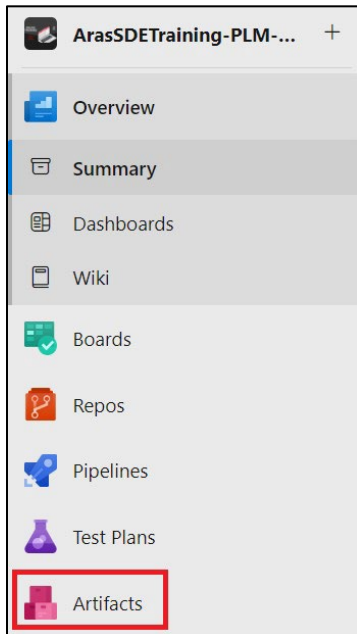

3. Select **Baselines** from the drop-down menu.

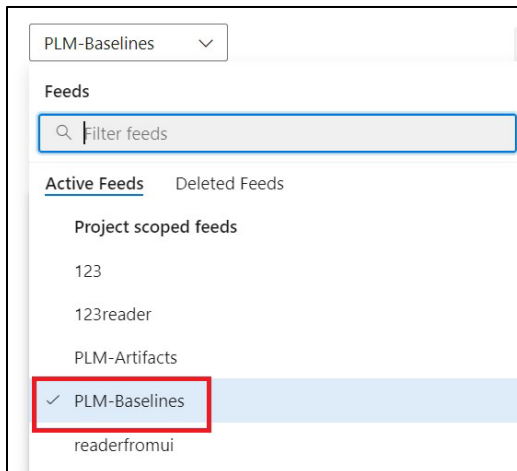

4. Select the available baseline(s) for the Aras Innovator release.

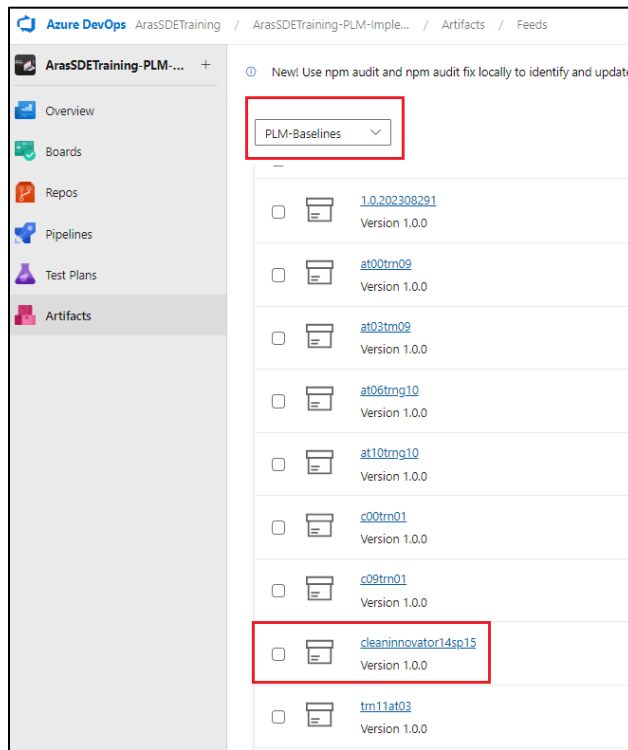

Aras provides the **CleanInnovatorxxSPyy** baseline for every new SDE. When selecting the baseline(s), the command line for downloading appears.

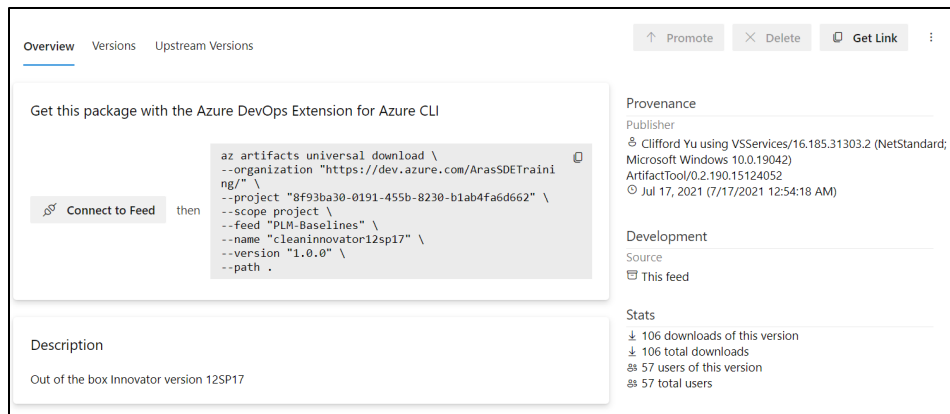

5. Run **Windows PowerShell** as an administrator.

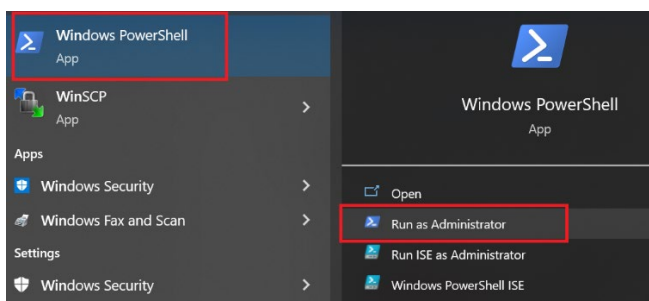

- Execute command: **az login**.

```
Administrator: Windows PowerShell
Copyright (C) Microsoft Corporation. All rights reserved.

Try the new cross-platform PowerShell https://aka.ms/pscore6

PS C:\windows\system32> az login
```

- Run the command to access the newly created folder in step 1:
`cd C:\ArasProjects\Baselines\Cleaninnovator14sp3.`
- Copy the command from **Azure DevOps** to download the baseline and run the command in **Windows PowerShell**.



```
Administrator: Windows PowerShell
Windows PowerShell
Copyright (C) Microsoft Corporation. All rights reserved.

Try the new cross-platform PowerShell https://aka.ms/pscore6

PS C:\windows\system32> az devops login --organization https://dev.azure.com/ArasSDETraining
Token:
PS C:\windows\system32> cd C:\ArasProjects\Baselines\Cleaninnovator14sp3
PS C:\ArasProjects\Baselines\Cleaninnovator14sp3> az artifacts universal download --organization "https://dev.azure.com/ArasSDETraining/" --project "8f93ba30-0191-455b-8230-b1ab4fa6d662" --scope project --feed "PLM-Baselines" --name "cleaninnovator14sp3" --version "0.0.1" --path .
Downloading Universal Packages tooling (ArtifactTool_win10-x64_0.2.267): 100.00% ..
```

The following files are visible in the newly created folder when the download is complete.

Name	Type	Size
CodeTree	Compressed (zipped)...	393,665 KB
DB.bacpac	BACPAC File	4,172 KB
DB.bak	BAK File	14,926 KB

3.2.3 Create Fork and Clone Repository

3.2.3.1 Creating Forks

A Fork refers to the process of creating a copy of a repository within the same organization or project. Forking a repository generates a new copy of the original repository, including all its code, branches, and commit history.

The following steps outline the process to create Forks:

1. From **Azure DevOps**, select **Repos**.

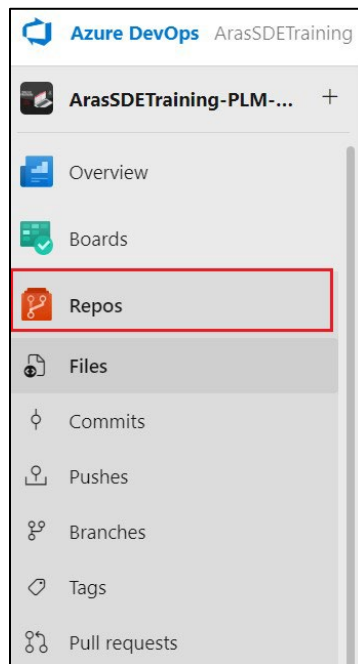

2. Locate and click the **Repository to Fork**.

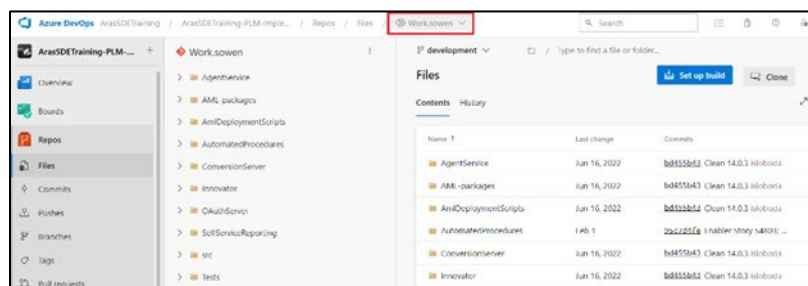

3. Click **More actions** and select **Fork**.

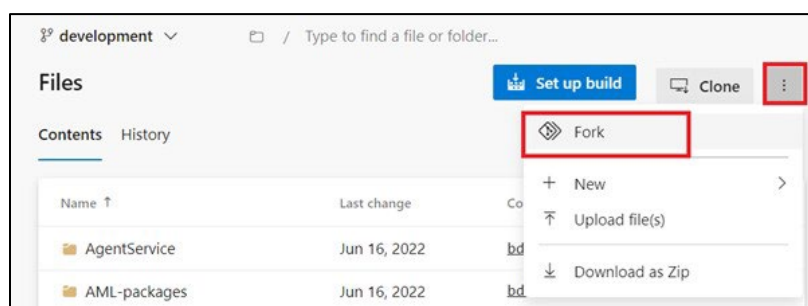

4. Select **All branches** and click **Fork**. The **Repository** name and **Project** is auto populated. Change the **Repository** name if needed. **Azure DevOps** creates the forked repository and redirects the user to its page once the process is complete. Users clone the forked repository to the local machine for making changes and push them back to the forked repository.

3.2.3.2 Cloning Repo to Local Working Directory

A complete copy of the project's codebase, commit history, and related files is created on a local machine when cloning the repository.

The following steps outline the process of cloning a repository to a local directory:

1. Select the fork to be cloned in **Azure DevOps** from the **Work** drop-down menu.

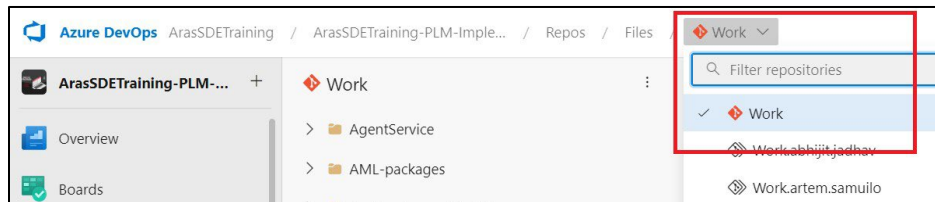

2. Click **Clone**.

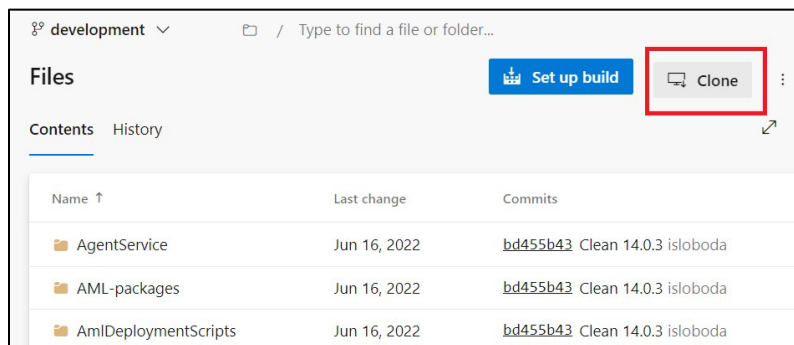

The Clone Repository dialog box appears with the repository's clone URL.

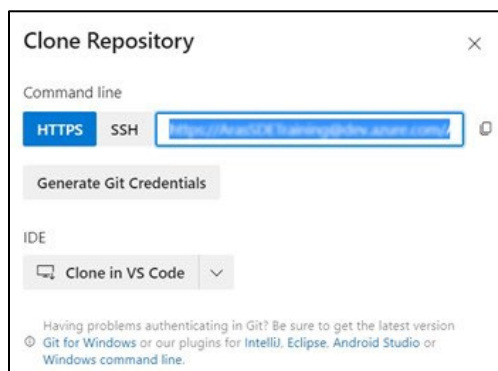

3. Copy the clone **URL (HTTPS or SSH)**. An example URL: https://dev.azure.com/{organization}/{project}/_git/{repository}. Use any version control tools required to clone the repository.
4. In the version control tool's interface, find the option to clone or create a new repository.
5. Paste the clone URL copied from the **Azure DevOps** project.

3. Run the following script: **repo-init.ps1**.

A few more files are added after the repo-init.ps1 script is run.

```

Administrator: Windows PowerShell

Directory: C:\ArasProjects\Project1\LocalRepo\MyFork

Mode                LastWriteTime         Length Name
----                -
d-----          5/23/2023 8:09 PM             .vscode
d-----          5/23/2023 8:09 PM             AgentService
d-----          5/23/2023 3:20 PM             AML_packages
d-----          5/23/2023 3:20 PM             AmlDeploymentScripts
d-----          5/23/2023 8:09 PM             AutomatedProcedures
d-----          5/23/2023 8:09 PM             ConversionServer
d-----          5/23/2023 8:06 PM             Documentation
d-----          5/23/2023 3:20 PM             Innovator
d-----          5/23/2023 8:09 PM             GithubServer
d-----          5/23/2023 8:06 PM             Resources
d-----          5/23/2023 8:06 PM             Sample Data
d-----          5/23/2023 8:09 PM             SelfServiceReporting
d-----          5/23/2023 8:06 PM             src
d-----          5/23/2023 3:20 PM             Tests
d-----          5/23/2023 3:21 PM             TransformationsOfConfigFiles
d-----          5/23/2023 8:09 PM             VaultServer
-a-----          5/23/2023 3:20 PM             106 .aras_binaries-ignore
-a-----          5/23/2023 3:20 PM             11877 .encoding.ignore
-a-----          5/23/2023 3:20 PM             2569 .eslintignore
-a-----         12/28/2022 9:13 PM             1393 .eslintrc.json
-a-----          5/23/2023 3:20 PM             7 .gitattributes
-a-----          5/23/2023 3:20 PM             23 .gitconfig
-a-----          5/23/2023 8:09 PM             5727 .gitignore
-a-----          5/23/2023 3:20 PM             5128 .jshintignore
-a-----          5/23/2023 3:20 PM             78 .shintrc
-a-----         12/28/2022 9:13 PM             582 ActivateInnovatorClientWatcher.ps1
-a-----         12/28/2022 9:13 PM             7645 build.ps1
-a-----         12/28/2022 9:13 PM             879 BuildAndDeploy.ps1
-a-----         12/28/2022 9:13 PM             3144 BuildDeploymentArtifact.ps1
-a-----         12/28/2022 9:13 PM             1155 CleanUp.ps1
-a-----         12/28/2022 9:13 PM             1483 ContinuousIntegration.ps1
-a-----          3/17/2022 2:33 PM             699 ConversionServerConfig.xml
-a-----         12/28/2022 9:13 PM             1810 DeployArtifact.ps1
-a-----          3/17/2022 2:33 PM             903 InnovatorServerConfig.xml
-a-----          5/23/2023 3:20 PM             441 NuGet.config
-a-----         12/28/2022 9:13 PM             5783 package.config
-a-----          5/23/2023 3:20 PM             4347 Readme.md
-a-----          5/23/2023 3:20 PM             46 Readme.txt
-a-----         12/28/2022 9:13 PM             9003 repo-init.ps1
-a-----         12/28/2022 9:13 PM             735 RunIntegrationTests.ps1
-a-----         12/28/2022 9:13 PM             732 RunSqlInteTests.ps1
-a-----          3/17/2022 2:33 PM             240 SelfServiceReportConfig.xml

PS C:\ArasProjects\Project1\LocalRepo\MyFork>
  
```

3.2.5 Local Environment Variables Set Up

A local environment is now established and connected to the Standard SDE.

The build and deployment scripts running in the SDE possess local equivalents that require specific details related to the given environment and the associated Git branch. Property settings provide these details.

The property values have the following precedence. They can be set or overridden based on this precedence. The highest is evaluated last as shown.

- **Default.Settings.include** – this file is located in “...\AutomatedProcedures\
- **Machine.Settings.include** – this file is located in “c:\” or alternate root directory
- **<ProjectPrefix>-<git-branch>.Settings.include** – the project Prefix is set in “Default.Settings.include” the git branch must match the branch that user check out

BuildAndDeploy.ps1 file is used to deploy Aras Innovator and the customization from the current directory.

The following steps outline the process to run BuildAndDeploy.ps1 in a local environment:

1. Open **Windows PowerShell** as administrator and go to the working directory. For example: C:\ArasProjects\project1\localRepo.



2. Run `.\BuildAndDeploy.ps1`.

When **BuildAndDeploy.ps1** script is run for the first time it does the several environment verifications, and creates following file:

`C:_machine_specific_includes\Machine.Settings.include`

```
You are about to get path to Machine Specific Includes directory...
Do you want to create directory 'C:\_machine_specific_includes'? [Y] Yes or [N] No (default is 'N'): Y
```

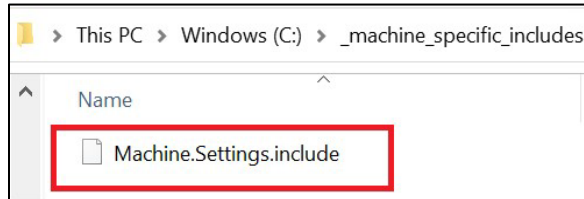

The **Machine.Settings.include** file contains series of key/value pairs that are used by the build process to build Aras Innovator on the local machine.

The prefix for the project and a reference to the last commit are used from an include file which is present in the following local repository:

`C:\ArasProjects\project1\localRepo\AutomatedProcedures\Default.Settings.include`.

The **Default.Settings.include** includes all the default properties required for a project.

When executing a script, a variable is first loaded from **Default.Settings.include**. If the same variable is defined into **Machine.Setting.include**, the value is overwritten. Finally, if the variable is defined in a branch specific file, the value is overwritten.

3. Update the **Machine.Settings.include** file with the following:

```
<?xml version="1.0" encoding="utf-8"?>
<project name="Default.Settings">
  <property name="Path.To.Baselines.Dir" overwrite="true" value="C:\ArasProjects\Baselines" />
  <property name="Path.To.DB.Bak" overwrite="true" value="C:\ArasProjects\Baselines\ArasSDETraining\CleanInnovator14SP3\DB.bak" />
  <property name="Path.To.CodeTree.Zip" overwrite="true" value="C:\ArasProjects\Baselines\ArasSDETraining\CleanInnovator14sp3\CodeTree.zip" />
  <property name="MSSQL.SA.Password" overwrite="true" value="" />
  <property name="MSSQL.Innovator.Password" overwrite="true" value="" />
  <property name="MSSQL.Innovator.Regular.Password" overwrite="true" value="" />
  <!-- Note: If you want to set licenses here, please make sure they have been removed from 'BranchSpecificSettingsFile' to avoid overwriting. -->
  <choose>
    <when test="!(string::starts-with((Version.Of.Installed.Innovator, 11)))">
      <!-- Here you can set all the properties specific to Innovator 11, in particular, the licenses -->
      <property name="Innovator.License.Type" overwrite="true" value="" />
      <property name="Innovator.License.Company" overwrite="true" value="" />
      <property name="Innovator.License.Key" overwrite="true" value="" />
      <property name="Innovator.Activation.Key" overwrite="true" value="" />
      <property name="Feature.License.Strings.List" overwrite="true" value="" />
    </when>
    <when test="!(string::starts-with((Version.Of.Installed.Innovator, 12)))">
      <!-- Here you can set all the properties specific to Innovator 12, in particular, the licenses -->
      <property name="Innovator.License.Type" overwrite="true" value="" />
      <property name="Innovator.License.Company" overwrite="true" value="" />
      <property name="Innovator.License.Key" overwrite="true" value="" />
      <property name="Innovator.Activation.Key" overwrite="true" value="" />
      <property name="Feature.License.Strings.List" overwrite="true" value="" />
    </when>
    <when test="!(string::starts-with((Version.Of.Installed.Innovator, 14)))">
      <!-- Here you can set all the properties specific to Innovator 14, in particular, the licenses -->
      <property name="Innovator.License.Type" overwrite="true" value="Unlimited" />
      <property name="Innovator.License.Company" overwrite="true" value="Aras Corporation" />
      <property name="Innovator.License.Key" overwrite="true" value="" />
      <property name="Innovator.Activation.Key" overwrite="true" value="" />
      <property name="Feature.License.Strings.List" overwrite="true" value="" />
    </when>
  </choose>
</project>
```

Project Specific Settings:

- **Path to baseline directory:** For example, [C:\ArasProjects\Baselines](#).
- **Path.To.DB.Bak:** File path to a “clean” copy of the Innovator solutions database. For example, [C:\ArasProjects\project1\Baselines\CleanInnovatorxxSPyy\DB.bak](#).
- **Path.To.CodeTree.Zip:** A file path to the CodeTree.zip archive which contains the code tree of production Innovator instance. E.g., [C:\ArasProjects\project1\Baselines\CleanInnovatorxxSPyy\CodeTree.zip](#).

Machine Specific Properties:

- **Innovator.License.Type:** This is typically “Unlimited”, “Version” or “Verified” depending on the key being used for this project.
- **Innovator.License.Company:** The licensed company name.
- **Innovator.License.Key:** A license key to be used for the installation. This can be obtained from <http://www.aras.com/support/LicenseKeyService/>
- **Innovator.Activation.Key:** An activation key for features that have been licensed for this project.
- **MSSQL.Server:** Name of the SQL Server instance. (Default is the local machine.)
- **MSSQL.SA.Password:** The password for the sa (system admin) login.
- **MSSQL.Innovator.Password:** Password for the Aras admin login (default is innovator)
- **Feature.License.Strings.List:** This is an optional property. It is required only when the user needs to set values to features such as TAF (Test Automation Framework) that is required as part of CI/CD.

3.2.6 Build and Deploy Locally

The cloned repository on the local machine contains the actual definition of the customization project. It is now time to deploy it on the local machine.

The following steps outline the process of building and deploying Aras Innovator locally:

1. Open a new session on **Windows PowerShell** as administrator and go to the working directory. For example: `C:\ArasProjects\project1\localRepo`.
2. Run **.\BuildAndDeploy.ps1**. If any errors occur, make corrections in the **Machine.Settings.include** file and run the same command again.

Once the process is complete, a new instance of Aras Innovator is deployed (the output from the batch file will indicate the URL). A new database is created based on the values provided in the settings file and Aras Innovator is ready to run.

[http://localhost/\[MachineName\]-\[Prefix\]-\[branch\]](http://localhost/[MachineName]-[Prefix]-[branch])

SQL Server DB is restored:

[MachineName] - [Prefix] - [branch]

```
[exec] Importing feature licenses to the all database components.
[exec]
[exec] The "root" user logon is enabled for 'Database' database.
[exec]
[exec] Print.Url.Of.Installed.Innovator:
[exec] -----
[exec]
[exec] *****
[exec] URL of configured Innovator is: http://localhost/BLR1-LHP-NB4406-ArasSDETraining-Training
[exec] *****
[exec]
[exec] SUCCEEDED.
[exec]
[exec] Press any key to continue . . .
[exec] Starting 'powershell.exe (-Command "subst t: /D")' in 'C:\ArasProjects\Project1\LocalRepo\MyFork\AutomatedProcedures\Targets'

BUILD SUCCEEDED
Total time: 21.3 seconds.

AdaptInnovatorForDeveloperEnvironment:

[nant] C:\ArasProjects\Project1\LocalRepo\MyFork\AutomatedProcedures\Targets\AdaptInnovatorForDeveloperEnvironment.xml
Buildfile: file:///C:/ArasProjects/Project1/LocalRepo/MyFork/AutomatedProcedures/Targets/AdaptInnovatorForDeveloperEnvironment.xml
Target Framework: Microsoft .NET Framework 4.0
Target(s) specified: _AdaptInnovatorForDeveloperEnvironment

_AdaptInnovatorForDeveloperEnvironment:

BUILD SUCCEEDED
Total time: 0 seconds.

BUILD SUCCEEDED
Total time: 593.8 seconds.
SUCCESS!!!
PS C:\ArasProjects\Project1\LocalRepo\MyFork>
```



3. Copy the URL and paste it in the browser.
4. Log in to Aras Innovator as an administrator with the following credentials:

Username: admin

Password: innovator



At this point, contributors have a basic work environment setup and are ready to contribute as a member of a customization project team.

As mentioned earlier, a central focus of DevOps is to instill a culture and discipline to ensure proper management of the solution development process and the transition of a well-managed solution configuration into business-critical operations.

The following two sections introduce two essential aspects of the DevOps culture and lean agile development in general.

3.3 Continuous Integration and Continuous Delivery (CI/CD)

Aras DevOps is based on Continuous Integration and Continuous Delivery practices.

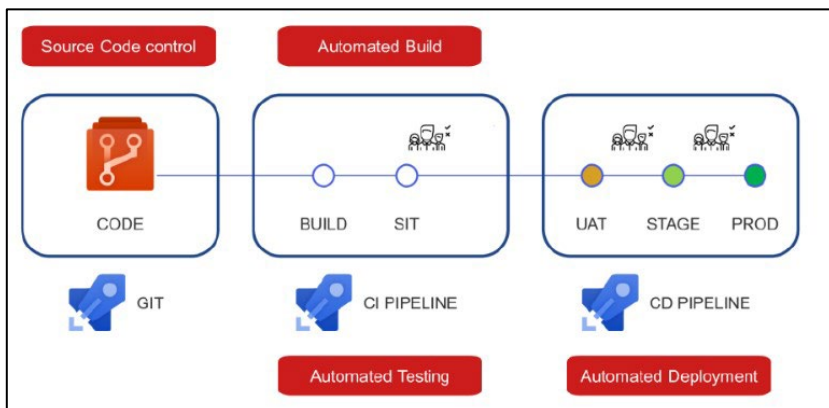

The above illustration shows the basic flow of Continuous Integration (CI) and Continuous Delivery process of merging code changes from multiple contributors to a single repository.

- Code = source code control. Source code control includes items such as AML Packages, configuration files and settings. It includes the code tree modification and the various libraries that constitute the solution.
- Commits are means to manage changes that take solution from one configuration to the next.
- The CI Pipeline supports continuous integration where various contributors use pull requests (PRs) to submit their contributions to the integrated solution. The system automatically builds and runs any available automated tests written by developers. If automated tests fail, the PR will fail. The developer will need to fix their code to successfully submit their PR. Reviewers check the work before accepting it.
- The resulting artifact that has successful pipeline are candidate to be deployed to System Integration Testing (SIT) instance for manual testing.

Continuous delivery is an approach where teams release quality products frequently and predictably from source code repository to production in an automated fashion. Once code has been tested and built as part of the CI process, continuous delivery takes over during the final stages to ensure it can be deployed as packaged, with everything it needs to deploy to any environment at any time.

Continuous delivery can cover everything from provisioning the infrastructure to deploying the application to the testing or production environment.

Note: When Aras DevOps is purchased separately (as opposed to within an Aras Enterprise subscription), the customer independently hosts the UAT, Staging, and Production environments on their own infrastructure. The creation of these pipelines falls completely outside the scope of Aras DevOps.

3.4 Testing

Testing is an integral part of agile and lean methodology:

1. **Continuous Improvement:** Regular testing provides feedback that aids in constant product refinement, catching bugs early, and improving quality.
2. **Customer Satisfaction:** Testing ensures the product meets customer requirements and functions as expected, enhancing user experience.
3. **Risk Mitigation:** Testing identifies potential issues early, reducing the risk of major problems and saving time and resources.
4. **Collaboration:** Testing fosters better communication and understanding between developers and testers.
5. **Rapid Delivery:** Continuous testing supports Agile and Lean's emphasis on frequent, incremental software delivery.
6. **Built-In Quality:** In Lean, quality is embedded in the development process, so every piece of code is tested as it's developed.
7. **Adaptability:** Testing ensures changes made during the project don't negatively impact the system.

The Aras Test Automation Framework (TAF) is a framework for writing and executing automated tests for the Aras Innovator platform included within Aras DevOps. It is a set of APIs that abstract the complexity of the underlying testing frameworks used – Selenium, NUnit and TestRunner. TAF greatly reduces the brittleness of automated tests as the underlying browser and application technologies change. The goal of TAF is to absorb the changes made by say, Google Chrome or Aras Innovator, such that tests written on one version for a piece of functionality continue to work on the next version of Aras Innovator for the same functionality.

TAF includes APIs for automated tests to cover:

- Web UI (Selenium)
- Integration (AML)

To support the demand of Continuous Integration and Continuous Delivery (CI/CD), automated testing increases an organization's ability to thoroughly test new functionality and applications as fast as they are developed. This framework is built to work with the Aras Innovator Platform to improve the speed, cost, and quality of the development process.

TAF has a framework for writing web functional tests and end-to-end tests that use the Aras Innovator Web Client like a real user.

The following section details the steps for an individual contributor to make changes within their Local Development Environment and submit it for integration into the SDE.

4 Contributor Process

Section 3.2 Local Development Environment (LDE) introduces the LDE, explaining the configuration process as well as the procedures for building and deploying a local instance of Aras Innovator.

This section outlines how to enable a contributor to make contributions.

4.1 The Contribution Process Overview

The developers, test/QA engineers and other stakeholders in a team are considered Contributors. The Contributors who may contribute source files (configuration files, source code C#, etc.) need to create a Fork to manage their work in the environment.

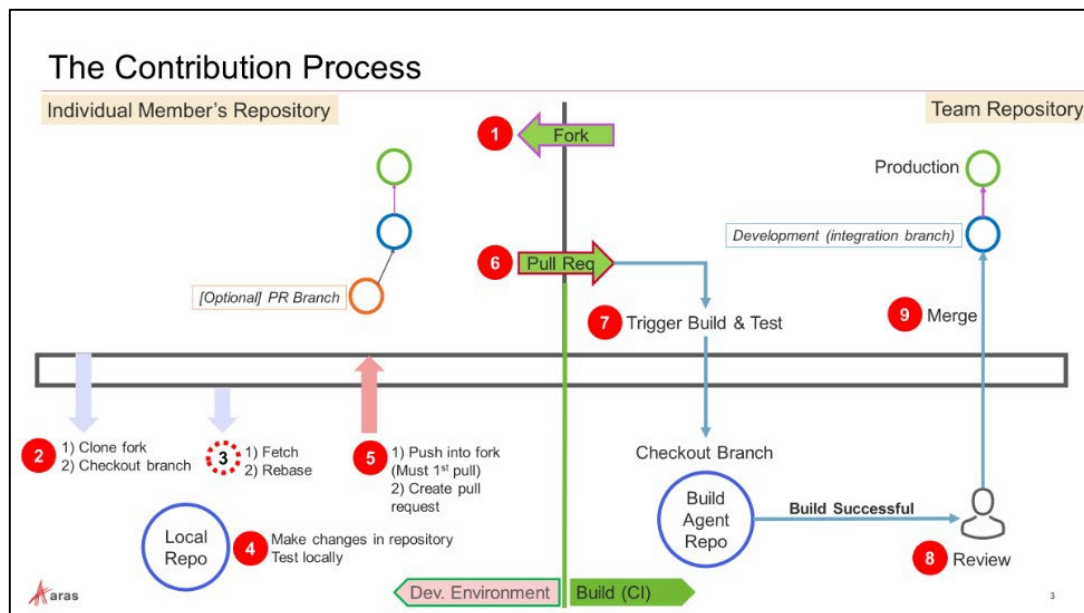

1. Create a Fork (copy of the shared team repository).
2. Clone the Fork to the local environment and check out the branch to work on.
3. Add a remote reference to the team repo to fetch and rebase the current work on it.
4. Make changes in the repository and test locally by running RunIntegrateTest, ContinuousIntegration, and other scripts.
5. Commit the changes locally and then push.
6. Create the pull request.
7. Updates to the source branch after the pull request is created and the initial creation triggers a ContinuousIntegration pipeline based on branch policy.
8. When the ContinuousIntegration pipeline has successfully built the artifact, it will run a test and report a green status or not. Based on that status, reviewers may approve the PR. They may also reject it even with a green build, if some other project practice is violated.
9. When the PR is approved and merged, the branch would typically have a policy to run the ContinuousIntegration pipeline again. This is to make sure that all PRs are still in sync. The goal is to ensure that the common repo branch is always buildable.

4.2 Adding Remote Reference

To incorporate the current work with the team repository and keep it up to date, the contributor needs to establish a remote reference. By adding this reference, the contributor creates a connection between the local repository and the shared team repository. This allows them to fetch the latest changes made by the team and rebase contributor's work on top of them. Cloning and other preliminary steps have already been completed; this reference addition is specifically meant for facilitating contributions.

The following steps outline the process of creating addition remotes:

1. Launch the chosen Version Control tool on the local machine.
2. Use the version control tool to navigate to the local repository where user wants to add the remote reference.
3. Find the option or command within the version control tool to add a remote reference or remote repository.

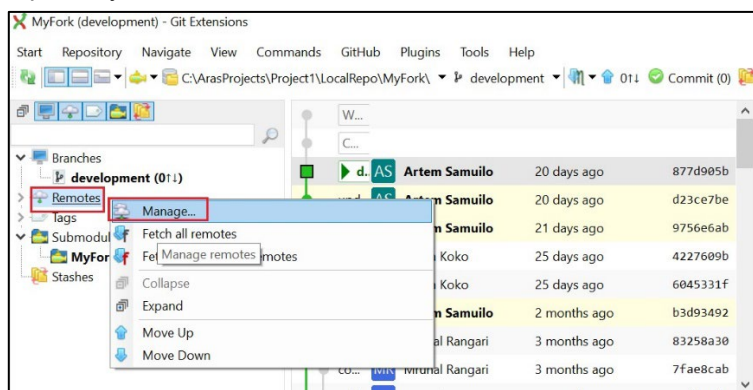

4. Click **+** icon to add a new remote.

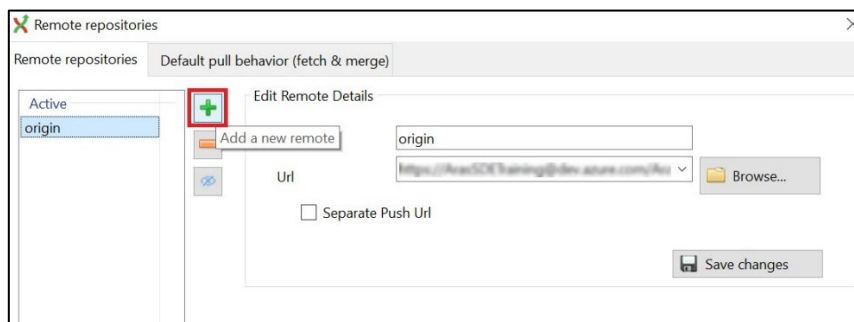

5. Enter the remote repository URL into the appropriate field or prompt within the version control tool.

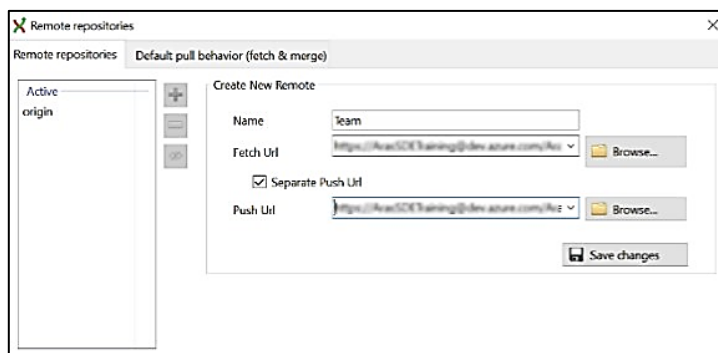

- Optional: Assign a name to the remote reference to make it easier to reference in the future.

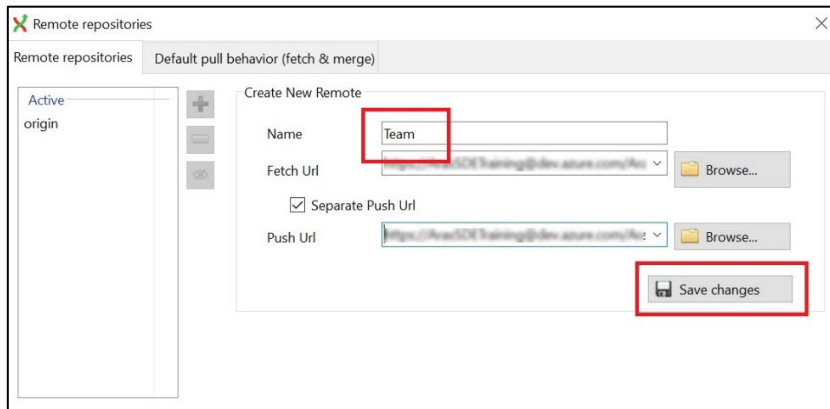

- Once the necessary details are entered and configured any optional settings Save and add the remote reference.

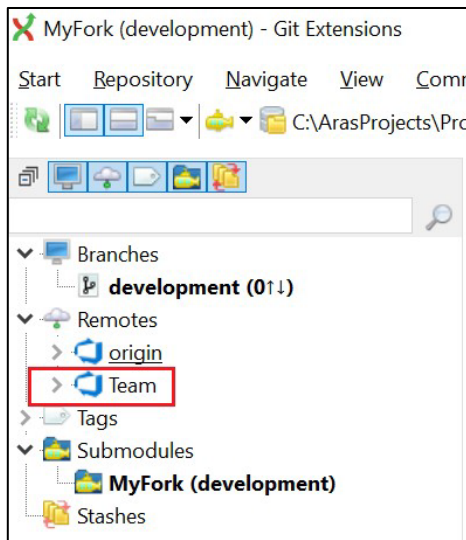

4.3 Making Changes in Local Repo

As an individual contributor, make changes in the Local Repo and test them locally before submitting them to merge into the team's work. Modifying the local repository of Aras Innovator involves making changes to the files and configurations stored on the local machine. These changes can include customizations to item types, forms, workflows, reports, and other aspects of the Aras Innovator solution.

4.4 Add or Modify file in Code Tree

If the **Nuget Package Aras.Crt.Core.1.1.XXX** is present in the project's package.config in the project repository, only new or changed files related to the project customization should be committed to the Git Repository. Users must commit any customized file into the **Code Tree** folder in the project repository.

The following steps outline the process of adding or modifying files in the code tree:

1. Identify the file that needs to be modified in the project repository.

For example, a user wants to make modifications to the file Inbasket.html (Innovator\Client\scripts\InBasket\InBasket.aspx) to fulfill UI requirements of the implementation.

2. To customize a service, create a folder with a service's name under the **Code Tree** folder in the project repository.

For example, user needs to recreate the following structure:

"CodeTree\Innovator\Client\scripts\InBasket" in the Git Repository, under **Code Tree** folder.

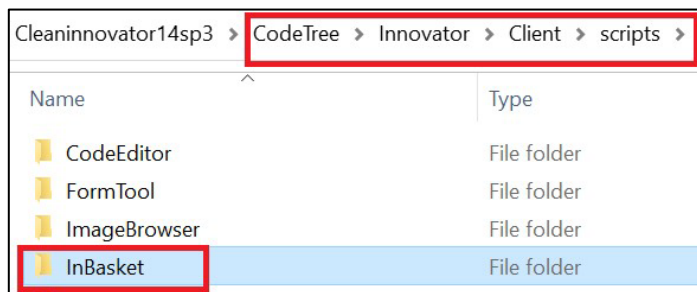

3. Commit the non-modified files before making any changes to those files.

Note: Configuration files should not be modified and committed in the repository. Transformation Config functionality must be used to make changes in configuration files.

4. Make the required modifications to the files.
5. Commit the modified files.

Note: To modify an existing file in the deployed instance, it is recommended to first make a clean commit and then perform the modification in a separate commit in order to preserve the history of the change for future developers. However, this is not required in order to deploy the modified file.

4.5 Exporting Packages

Once the changes made in the Package Definition are complete, the package can be exported using the Export utility. This utility is a separate executable named export.exe that is available on the Aras Innovator CD image, or that may be downloaded from <https://www.aras.com/en/support/downloads>.

The Export utility selects a Package Definition from the database and creates a package folder structure in the file system. Each Package Group (ItemType, Form, etc.) becomes a separate subfolder in the file. Within each subfolder, each exported Item is represented as an AML file with the same name as the exported Item.

The following steps outline the process of running the export utility tool:

1. Download the Export utility from <https://www.aras.com/en/support/downloads>.
2. Run the export.exe as administrator.

4.5.1 Make Required Changes in Aras Innovator Instance

Login into the Innovator Instance and make customizations as per the project requirements.

4.5.2 Export Package After the Changes

Once all the changes are made to the Aras Innovator instance, it's now time to export those changes.

The following steps outline the process of exporting the packages after the changes:

1. Create a folder to export the changes made. For example, "C:\ArasProjects\Project1\Local Exports\Form Export 2".

All the data which is exported will be stored in the folder that is created in step 1.

2. On the export utility tool do the following:
 - Server: Enter the Aras Innovator server URL
 - Login in (fill in username admin and password, then click the login button).
 - Set the new destination of the export, all the exported files will be stored in that directory. For example: C:\ArasProjects\Project1\Local Exports\Form Export 2
 - In the Packages section, click on the ellipsis button.
 - Locate the package definition that is changed and select Items.

3. Click the **Export** button.

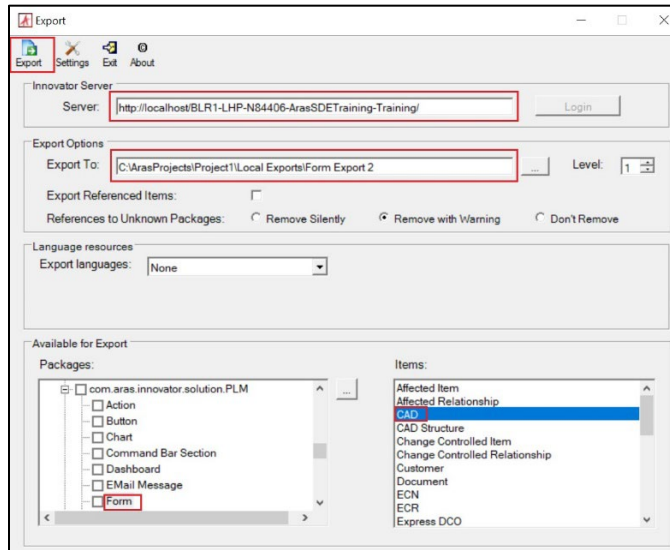

4.6 Copying the Export Utility's Output to the Local Repo

Once the changes are made and the files are exported, copy the top common folder and paste it into the local working directory of the repository (AML-Packages). During this process, be sure to accept any file replacement warnings that may appear.

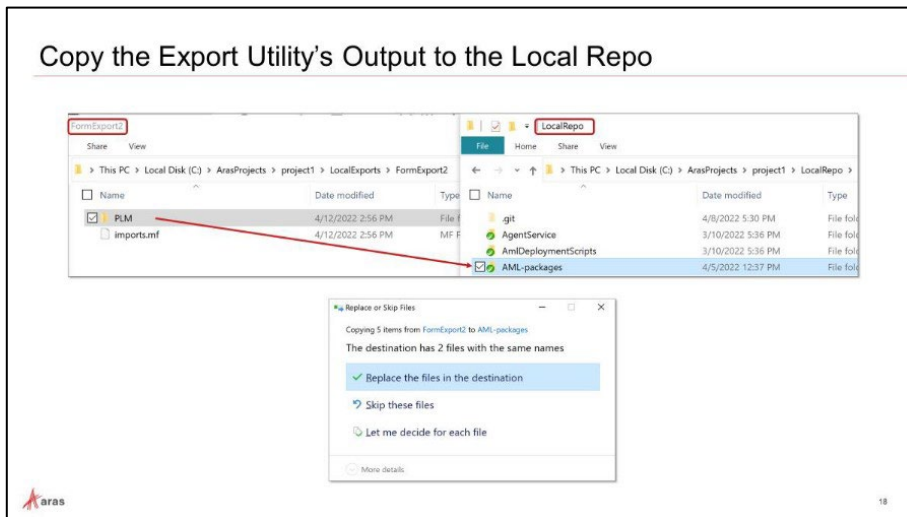

4.7 Staging Modified Files

Once the necessary changes have been made to the file, it is important to stage it before committing the changes to the version control system (Git). By staging the modified file, the user is preparing it to be included in the next commit, ensuring that the changes will be properly recorded and tracked within the version control system (Git).

The following steps outline the process of Staging the modified file:

1. In the terminal (Terminal, Git Bash, or Windows Command Prompt), navigate to repo in which the newly exported file is copied. For example: `C:\ArasProjects\project1\LocalRepo\AML-packages\PLM`.

2. Verify the status of the repository by running command.
3. Stage a file.
4. Verify now the new status of the repository.
5. Commit the file.
6. Confirm the changes in the Version Control System.

4.8 Continuous Integration Script

An automated utility script is provided as part of each customer repository to perform final validation and verification that a build is successful.

This script can be run by developers or system integrators manually to determine if the build passes or fails. Automation tools are also available to provide scheduled executions of this script on a dedicated CI server.

The CI script runs all the unit and integration tests that have been created for a project by installing and building a new instance of Aras Innovator, applying the project code and configuration, and making sure all tests are successful.

A report indicates Success or Failure with a running log if issues need to be resolved. The script then deletes the running instance (and database).

4.9 Test the Deployment Locally

Aras Innovator should be redeployed using the script `./BuildAndDeploy.ps1`. A green success message will appear upon successful execution.

```
Administrator: Windows PowerShell
[exec] Importing feature licenses to the all database components.
[exec]
[exec] The 'root' user logon is enabled for 'Database' database.
[exec]
[exec]
[exec] Print.Url.Of.Installed.Innovator:
[exec] -----
[exec]
[exec] URL of configured Innovator is: http://localhost/BLR1-LHP-N84406-ArasSDETraining-Training
[exec] -----
[exec]
[exec] SUCCEEDED.
[exec]
[exec] Press any key to continue . . .
[exec] Starting 'powershell.exe (-Command "subst t: /D")' in 'C:\ArasProjects\Project1\LocalRepo\MyFork\AutomatedProcedures\Targets'

BUILD SUCCEEDED

Total time: 21.3 seconds.

AdaptInnovatorForDeveloperEnvironment:

[nant] C:\ArasProjects\Project1\LocalRepo\MyFork\AutomatedProcedures\Targets\AdaptInnovatorForDeveloperEnvironment.xml
Buildfile: file:///C:/ArasProjects/Project1/LocalRepo/MyFork/AutomatedProcedures/Targets/AdaptInnovatorForDeveloperEnvironment.xml
Target framework: Microsoft .NET Framework 4.0
Target(s) specified: _AdaptInnovatorForDeveloperEnvironment

_AdaptInnovatorForDeveloperEnvironment:

BUILD SUCCEEDED

Total time: 0 seconds.

BUILD SUCCEEDED

Total time: 593.8 seconds.

SUCCESS!!!
PS C:\ArasProjects\Project1\LocalRepo\MyFork>
```

The following steps outline the process of Rebuilding the Aras Innovator:

1. Open Windows PowerShell and run as Administrator.

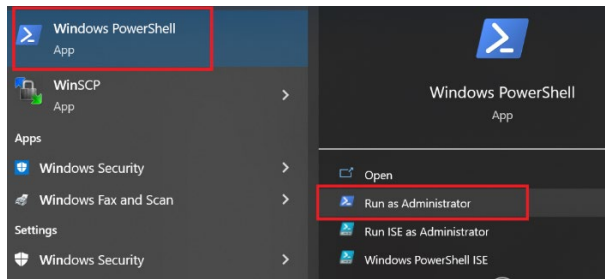

2. Access the local repository: C:\ArasProjects\project1\LocalRepo.
3. Run ./BuildAndDeploy.ps1 script.

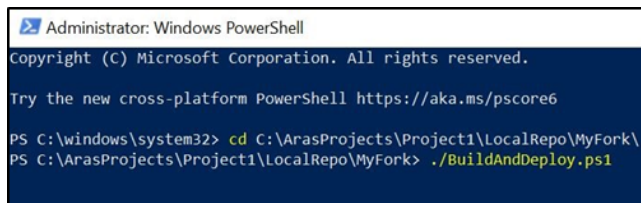

4. Review the changes made in the newly rebuilt Innovator instance.

4.10 Pushing Changes to Fork

Before creating a Pull Request to share the work with the rest of the team, the developer needs to push the changes to the Fork. By pushing the changes, a developer makes those changes available for others to review, collaborate, and merge into the original repository if required.

A fork in Git refers to a copy of a repository that is created in a developer's local repository. Forking allows users to contribute to an open-source project or collaborate with others without affecting the original repository.

4.10.1 Fetching Changes/Rebasing

While the implementation was in progress, it is possible that modifications or updates were made and pushed to the team repository. Hence, it is important to fetch the latest state of remote repository and rebase our changes on top.

Using the desired version control system, fetch the changes. The screenshot provided below serves as a visual representation, illustrating an example of the fetching process performed using Git Extension.

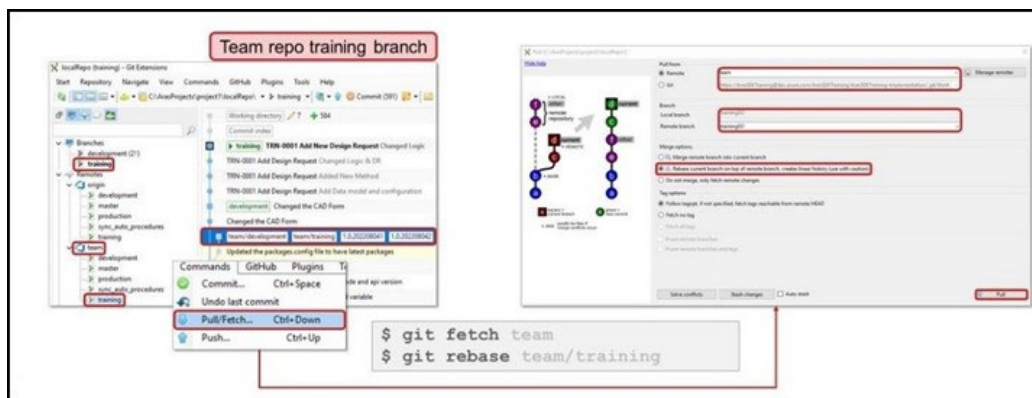

4.10.2 Pushing Changes to Fork

Before creating a Pull Request to share the work with the rest of the team, it is important to push the changes to the Fork. The screenshot provided below serves as a visual representation, illustrating an example of the pushing changes to Fork performed using Git Extension.

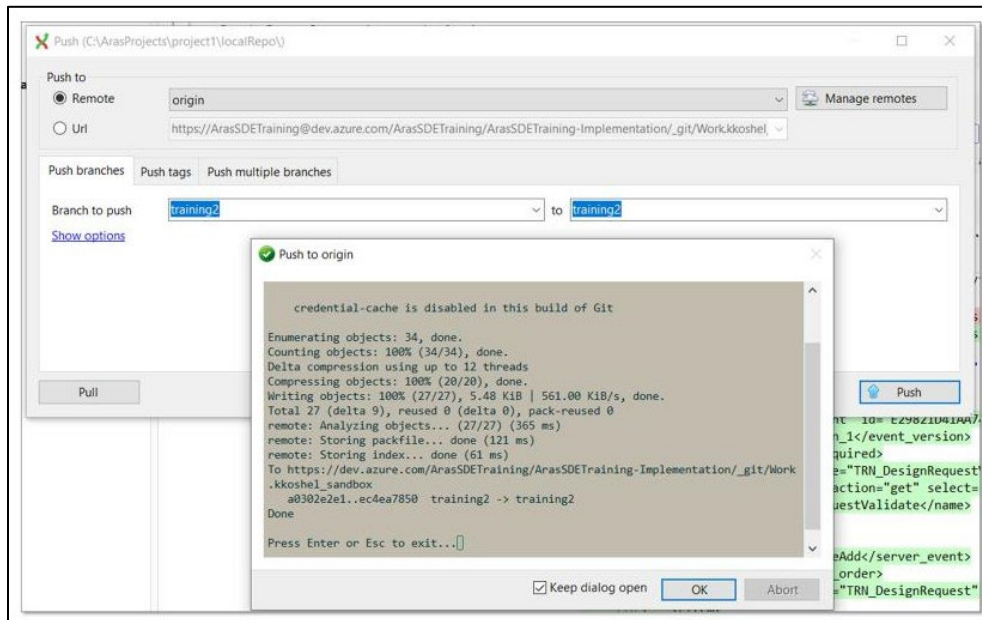

4.11 Creating a Pull Request

Pull Request Features

A pull request (PR) is a way for developers to propose changes to a codebase and collaborate with others to review and merge those changes. Some of the key features of a pull request include:

- **Code Changes:** A pull request includes the changes made to the codebase by the developer. The changes can be viewed and reviewed by other developers, and any feedback or comments can be added directly to the pull request.
- **Discussion and Feedback:** Pull requests provide a platform for developers to discuss and give feedback on the proposed changes. This allows for collaborative review and discussion of the code, ensuring that any issues are caught and resolved before the changes are merged into the codebase.
- **Automated Tests:** Pull requests can be configured to run automated tests, ensuring that the changes don't break existing functionality. This helps to catch any issues early on before the code is merged into the codebase.
- **Reviewers:** Pull requests can be assigned to specific reviewers who are responsible for reviewing the proposed changes. Reviewers can add comments and suggestions and approve or reject the changes before they are merged.
- **Status Checks:** Pull requests can be configured to include status checks, which can be used to verify that the changes meet certain criteria before they are merged. For example, a status check might ensure that all automated tests pass, or that the code meets certain coding standards.
- **Mergeability:** Pull requests are merged into the codebase once they have been reviewed and approved. This ensures that the changes are properly integrated into the codebase, and that any conflicts with other changes are resolved.

The following steps outline the process of creating a pull request:

1. Navigate to <https://dev.azure.com/{organization}/{project}>.
2. Go to **Repo** and select **Pull requests**.

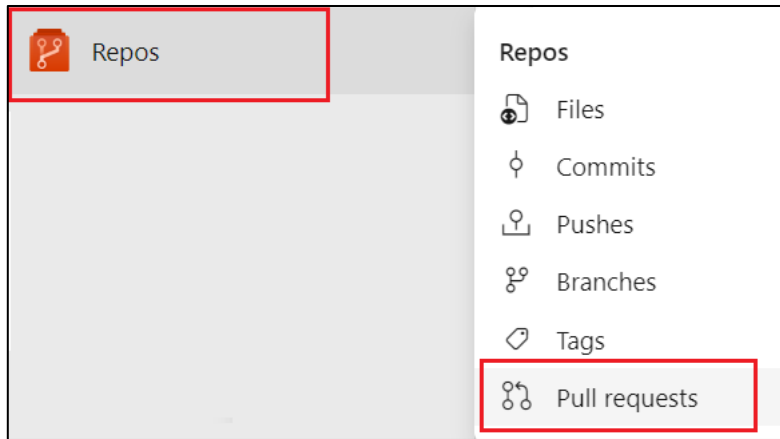

3. Click **New pull request**.



The New pull request form appears as follows:

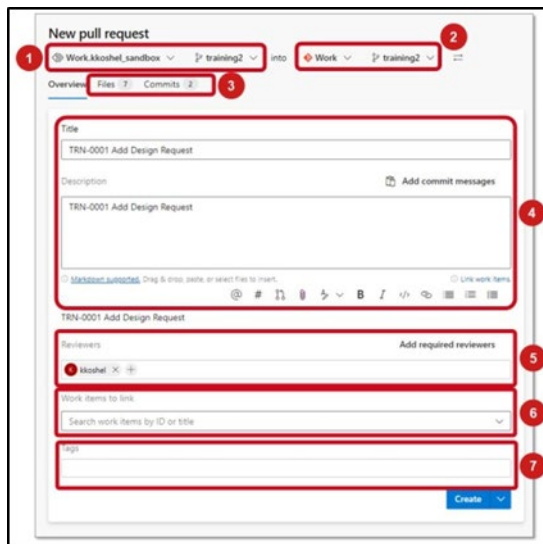

4. Enter the details as follows:

- **Source Repo/branch:** User'sFork
- **Target Repo/branch:** team repo
- Review the files/commits to be included
- **Title and Description:** User Story name
- Select reviewers
- Add Work items to link: Identify Work Items in the Azure DevOps as applicable
- Tags – if needed

5. Click **Create**.

4.12 Trigger, Build and Test

The contributor's contribution is built and validated through the CI pipeline. The pull request will trigger the CI pipeline, which will run tests and checks against the changes.

4.13 Reviewing a Pull Request

Each developer does not have push (or write) access to the central remote repository, they must issue a pull request so that code reviewers may inspect their work. The code reviewer then examines their work, approves (or rejects) it, and applies changes to the central repository or communicates with the developer to make corrections.

The following steps outline the process of Reviewing a Pull Request:

1. Navigate to <https://dev.azure.com/{organization}/{project}>.
2. Go to **Repos** and select **Pull requests**.

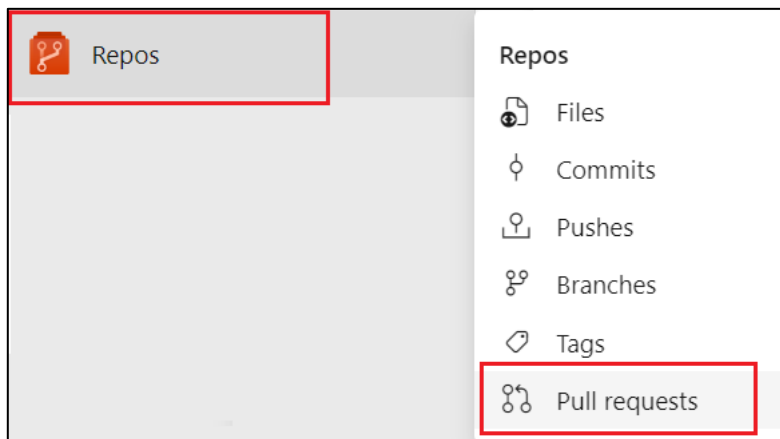

3. In the **Active** tab select the required pull request.
4. In the **Overview** tab of a PR, see the title, description, reviewers, linked worked items, history, status, and comments. Read the PR description to see the proposed changes. View the comments to understand the issues raised by other reviewers.

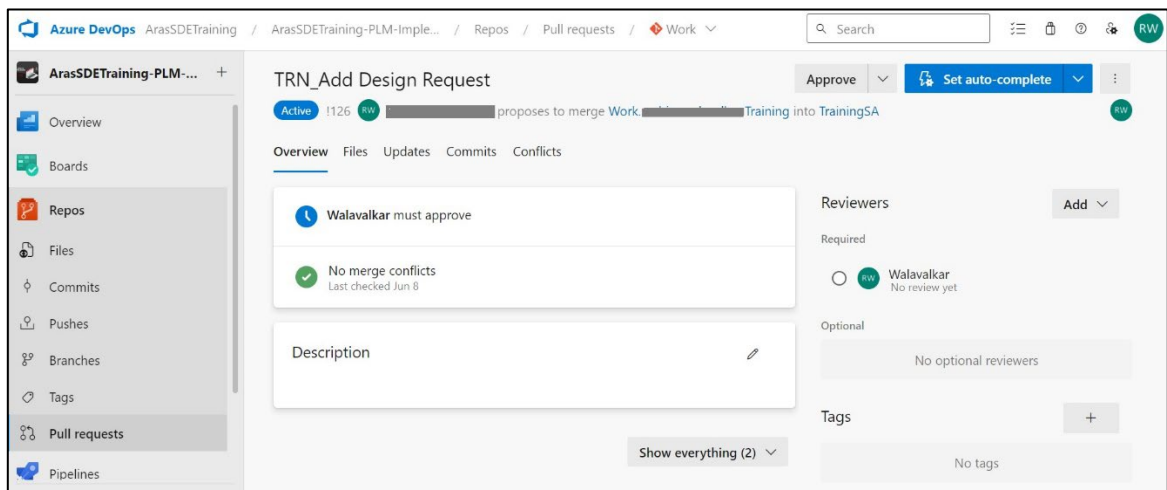

- Select the **Files** tab to review all content changes in the PR's source branch. The initial view shows a summary view of all file changes. Choose the View button next to a file to view only that file's changes. If the file was modified, the View button opens a diff view. If the file was added or deleted, the View button opens a content pane.

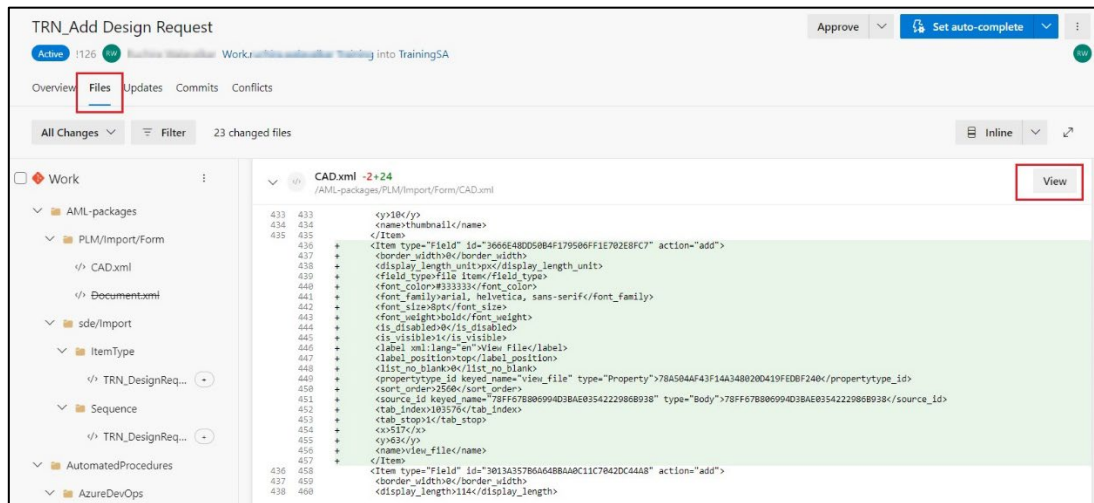

- In a diff view for a file, select either a Side-by-side or Inline diff layout.
- To review the changeset introduced by specific pushes to the source branch, select one or more changesets from the **Changes** drop-down list. When one or more changesets is selected, the diff view updates to show only the changes from the selected changesets. This feature is useful when changes have been pushed to the PR since the last review and the user just wants to see the new changes. The changes dropdown list names each changeset with the commit message from the final commit in each push operation.
- Choose the **Updates** tab to view all pushed changesets to ensure any source branch changes are not missed. The changesets are numbered and the most recent changeset appears at the top of the list. Each changeset shows the commits that were pushed in that push operation. A force-pushed changeset won't overwrite the changeset history and will show up in the changeset list same as any other changeset.

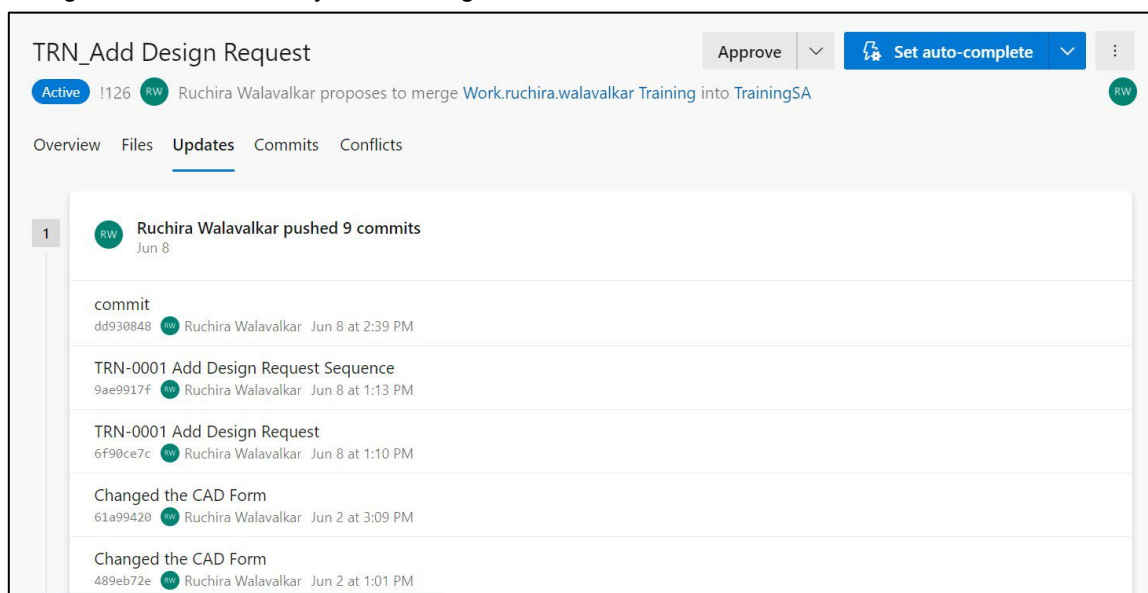

- Choose the Commits tab to view the commit history of the source branch after it diverged from the target branch. The commit history in the Commits tab will be overwritten if the PR author force-pushes a different commit history, so the commits shown in the Commits tab might differ from the commits shown in the Updates tab.

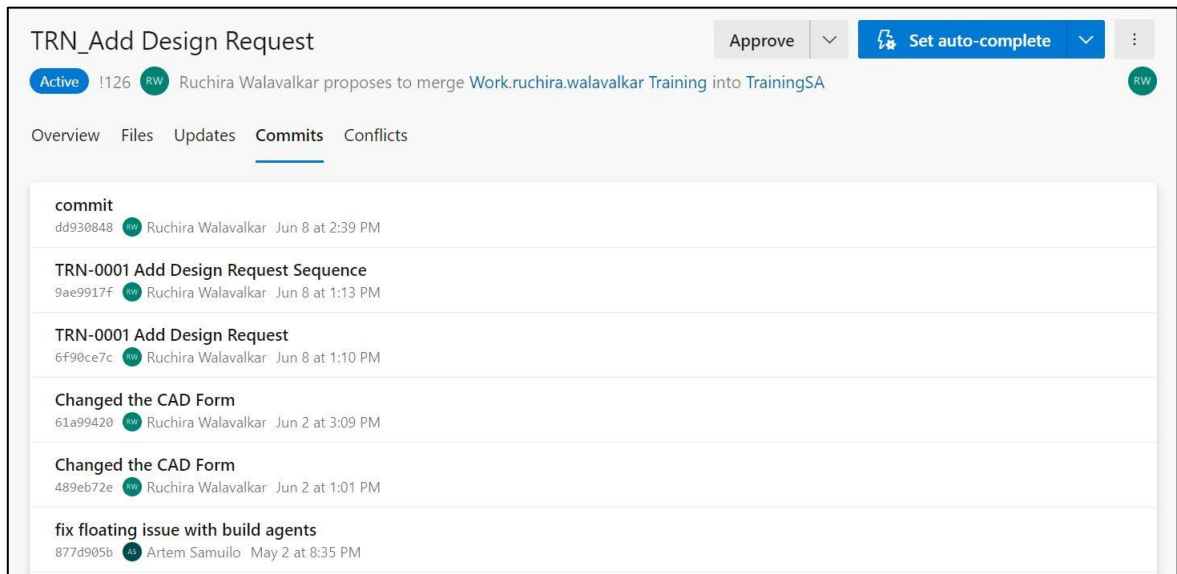

- In case there are any issues or questions about the changes provided by the developer, the reviewer can leave a comment for the developer. In the left panel, select the Method file and hover over the line to comment on and select the comment button to open an inline comment box. The user can also select multiple lines and then select the comment button that appears when hover over those lines.

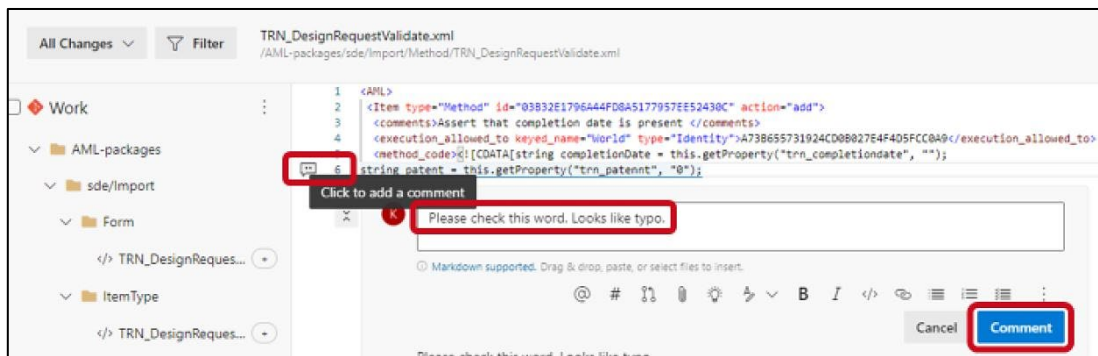

- As the author of the PR the developer needs to resolve the comment by taking the appropriate action, i.e., make the changes in their local repository, and then submit the change for approval through the PR request workflow.

4.14 Merging the Pull Request

If the reviewer agrees with the proposed changes, the Merge operation combines changes into the central repository.

When the Merge button is clicked by the reviewer the developers' proposed commit(s) are then merged into the central repository (team repo).

The following steps outline the process of **Merging the Pull Request**:

- Navigate to <https://dev.azure.com/{organization}/{project}>.

2. Go to **Repos** and select **Pull requests**.

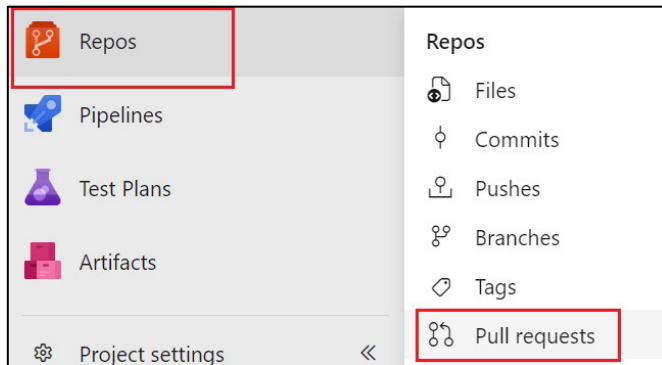

3. In the **Active** tab select the required pull request.

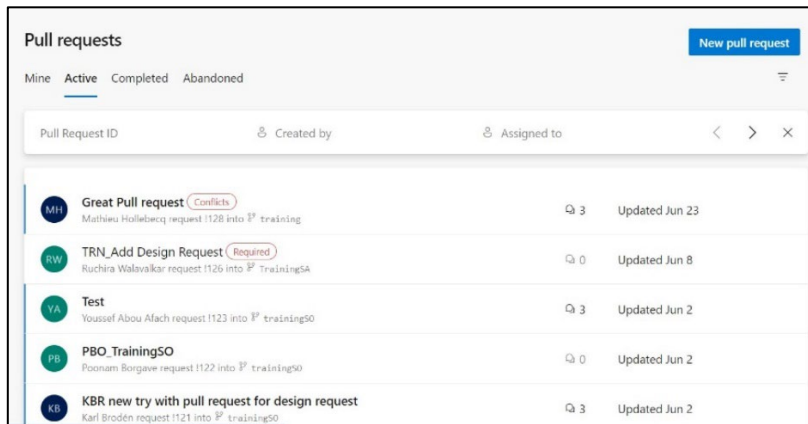

4. Select **Complete** on the upper right to complete the PR.

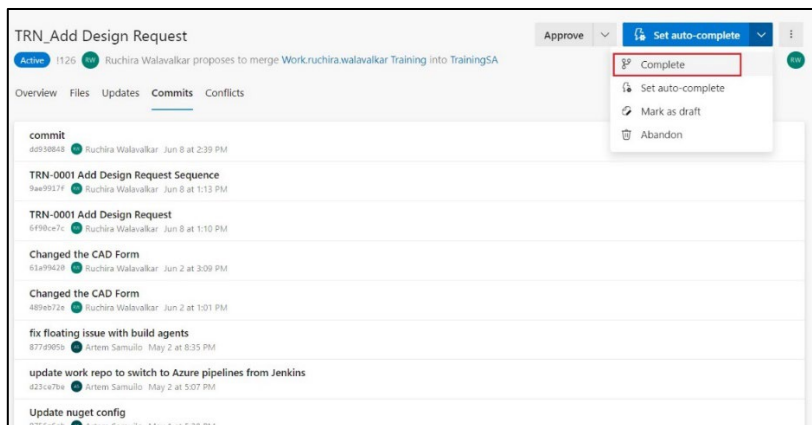

- In the Complete pull request pane, under **Merge type**, select **Rebase and fast-forward** and click on **Complete merge**.

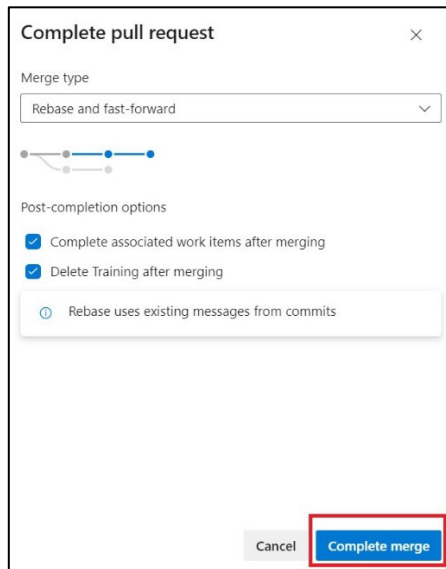

The completion of the PR triggers a new build.

- Verify that the build is “green” (successful) by navigating to **Pipelines > Pipelines** and select **Recent** tab.

5 Preparing the Project's Initial Baseline

A Clean Baseline refers to the original or initial plan at the beginning of a project, which is free from any changes. It represents the unaltered version of the project plan, typically provided by the project management team or stakeholders at the beginning of the project.

A baseline serves as a reference point and a point of comparison throughout the project's life cycle. It helps in tracking and managing project progress, identifying deviations from the original plan, and assessing the impact of changes and risks as the project evolves.

The diagram below offers an understanding of Aras Innovator's structure, comprising a platform and various applications. When the SDE is delivered, it includes the platform, and the specific project can choose the necessary applications and components. Making these decisions early on and creating a new project baseline is usually advantageous. This baseline acts as the starting point for further solution development. Refer to section 6 Baseline Management below to understand about building a baseline.

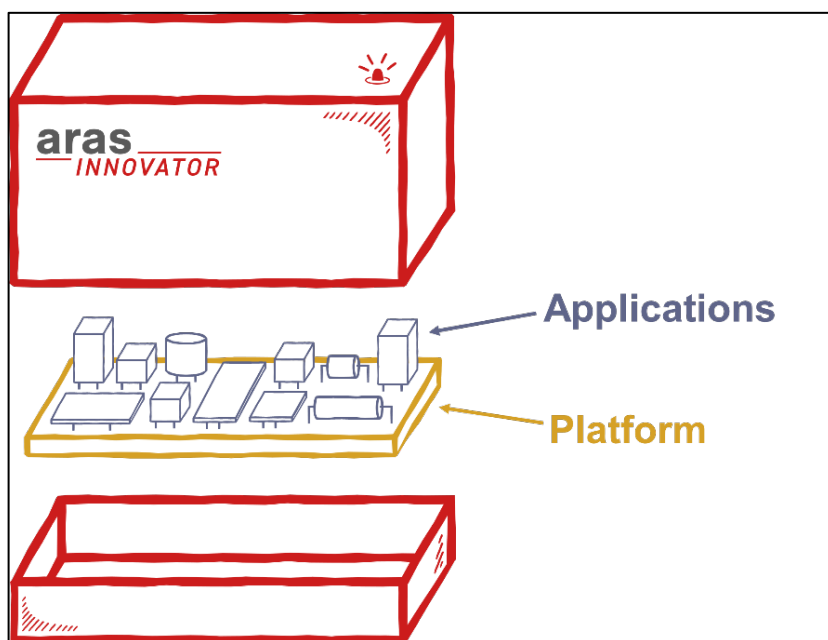

6 Baseline Management

When a project team receives the SDE from Aras, a baseline is established, which acts as the starting point for all future changes to the software. The execution of the setup script (BuildAndDeploy.ps1) installs an initial database and sets up all required files in the code tree directory.

The established baseline then becomes the foundation over which changes are layered each time the setup scripts are run.

As these changes accumulate over time, they may grow significantly larger. Therefore, generally, when the solution enters production, a fresh baseline incorporating all customizations can be set. This new baseline will then be the starting point for the setup scripts.

After Aras has provided an initial baseline, the project team can make modifications as needed. This may include:

- **Add new application to the platform:** Adding applications to a platform involves enhancing the functionality and broadening the capabilities of the system. An example of integrating an application into Aras Innovator is demonstrated in the section Appendix III: Adding Applications to a Project.
- **Add Language packs:** Adding language packs to software is a crucial step in making applications accessible and user-friendly to a diverse global audience.
- **Establish new baselines:** A new baseline provides a snapshot of the project's status, including what has been achieved and the resources expended to reach this point. Once established, this new baseline serves as the starting point for subsequent phases or steps in the project. See section 7.2 Generate New Baseline for more details.
- **Deploy build to SIT (for QA):** SIT involves testing the system as a whole in an environment that closely mirrors production to ensure that all integrated components work together as expected. This includes making sure new applications function correctly with the existing system and that language packs work as intended. See section 7.1 Deploy to System Integration Testing (SIT) Environment for more details.

When an SDE from Aras is received, and a baseline is established, it isn't a final process. It is instead an ongoing effort, and modifications to the software are carried out over time as the project requirements evolve. These modifications might include integrating new applications, adding new features, fixing bugs, and improving system performance among other things.

However, this process should be handled appropriately. Changes to the software must align with the project's goals, and they should not introduce new issues or conflicts. Therefore, comprehensive testing should be performed after each modification to verify that the changes are working as expected.

Reducing build time is another important aspect of this process. When modifications are organized and managed properly, the time required to build the software can be significantly reduced. This efficiency can lead to quicker deployments and an overall shorter time to market, which can be a significant advantage for the project.

Finally, it is essential that all these activities be carried out as part of a deployment policy. A deployment policy outlines the standards and procedures for making changes to the software, testing those changes, and deploying the software to the production environment. This policy helps ensure that all changes are carried out in a controlled and consistent manner, which can contribute to the overall quality and success of the project.

7 Pipelines

A pipeline is a set of automated processes that allow developers to build, test, and deploy their code consistently and reliably.

Aras provides following set of **Pipelines**:

1. **Continuous Integration** - This pipeline runs a build given a commit in the Git repo. The system triggers it in one of the following ways:
 - Validation for a branch
 - Validation for a pull request
 - Request by a DevOps user.
Typically, the Continuous Integration (CI) pipeline is not manually initiated; rather, it's automatically triggered by actions such as Pull Requests (PRs) and mergers, governed by branch policies.
2. **DeployToSIT** - This pipeline creates a deployment package from a build, deploys it to the SIT environment, and stores a copy in the Artifacts storage.
3. **DeleteInnovator** - This pipeline deletes a given test instance in the SIT environment.
4. **GenerateBaseline** - Generating baselines establishes a starting point and facilitates tracking changes in the projects. This pipeline generates a new baseline and stores the artifact in the artifact storage.

7.1 Deploy to System Integration Testing (SIT) Environment

Deploying on SIT allows developers and testers to assess the behavior and performance of the Aras Innovator in a simulated production-like setting before it is deployed to the actual production environment.

The following steps outline the process of deploying Aras Innovator to SIT:

1. Navigate to <https://dev.azure.com/{organization}/{project}>.
2. Identify the build to deploy.
3. Select the **DeployToSIT** pipeline and click **Run Pipeline**.

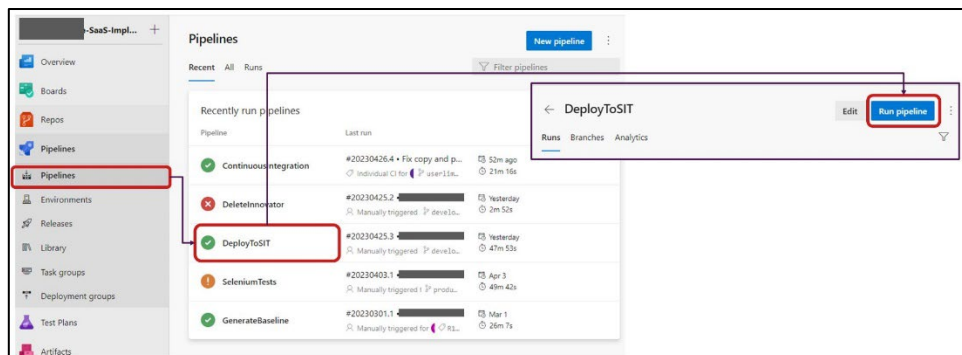

- Select the branch in the Work repo and click on **Resources**.

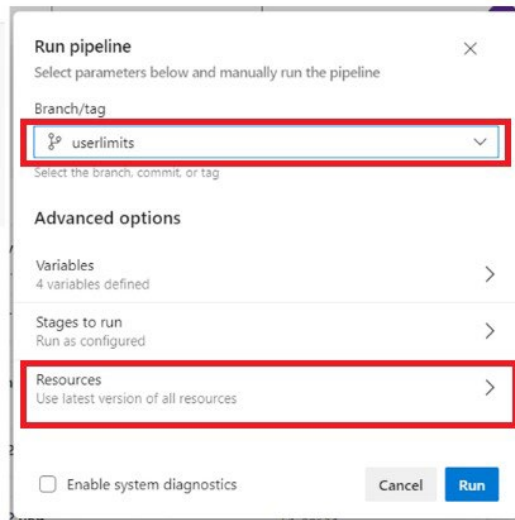

- Click **ContinuousIntegration** (last successful run) and select the required run.

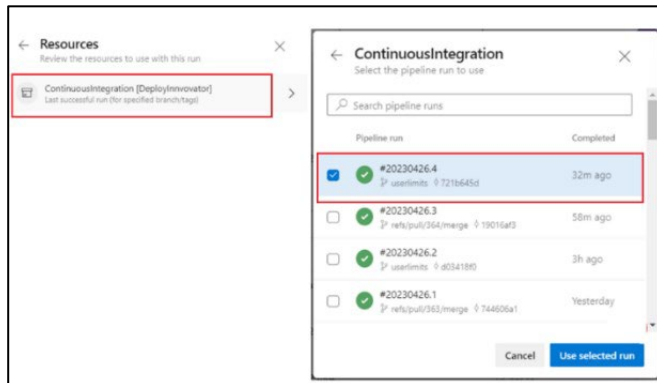

- Click **Use selected run**.
- Navigate back to **Run Pipeline** dialog box and click **Run**.

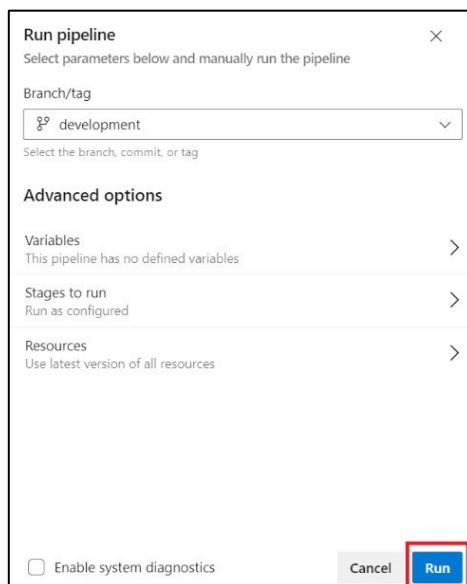

8. Optionally: Click **Deploy** link to watch the progress.
9. When the pipeline is completed, a link of the new instance should be available on the wiki page for testing.

7.2 Generate New Baseline

7.2.1 Creating Tag on Last Approved Commit

When the Aras Innovator is installed for the first time, a Git tag is used to mark the starting point and it uses the following format: CleanInnovatorxxSPyy, where xx = the version and yy = the Service Pack number of the base platform.

Define the Git Tag on the last approved commit. The pull request (PR) process must be completed to get the tested commit that is proposed as the new baseline to the destination (Central Repo) branch. The commit must be tagged.

The following steps outline the process of Creating Tag on Last Approved commit:

1. Navigate to the <https://dev.azure.com/{organization}/{project}>.
2. Click **Repos** and select **Commits**. Select the corresponding successful commit.

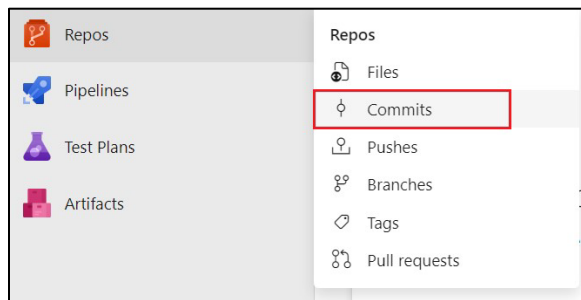

3. Click **More** options menu and select **Create tag ...**

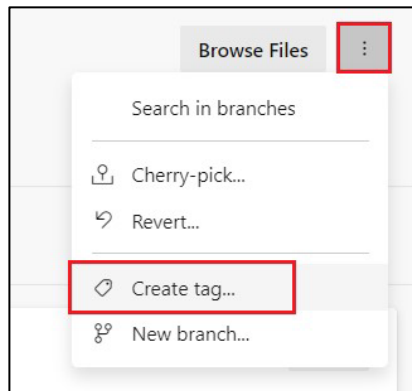

4. Enter the following details in the **Create a tag** dialog:

- Name: Name of the tag
- Based on: Commit above
- Description: Tag Description

Select an appropriate baseline naming convention. For most projects without features it is sufficient to use Project [prj] baseline [bl] and numbers. Example: prjbl001 – for user's first baseline

After each product release it is also recommended that user must have prdbl001 – production baseline

Some projects may have several workstreams (features) with different go-live dates. For such projects, the team may include feature designations as in the example mbsebl01 (Model-Based Systems Engineering) bl (Baseline) 01 → mbsebl01.

5. Click **Create**.

7.2.2 Running the Baseline Pipeline

The following steps outline the process of running the baseline pipeline:

1. Navigate to the Navigate to <https://dev.azure.com/{organization}/{project}>.
2. Click **Pipelines** in the left menu and select **Pipelines**.

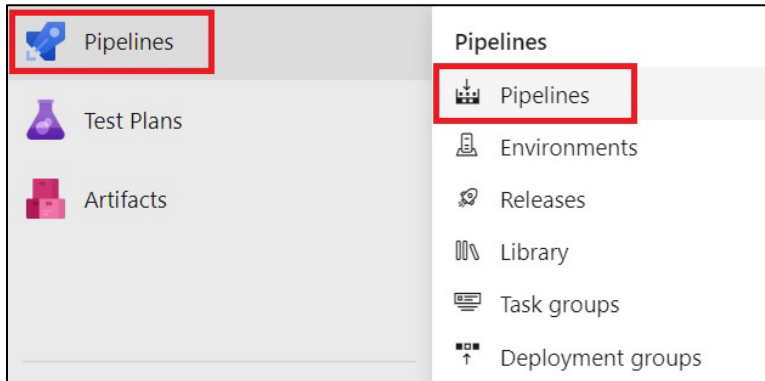

3. Click **GenerateBaseline** pipeline.

Pipeline	Last run
SeleniumTests	#20230623.1 • added SDE09 with new item and corresponding artifacts ↳ Manually triggered for development
ContinuousIntegration	#20230623.9 • added SDE09 with new item and corresponding artifacts ↳ Scheduled for development
DeployToSIT	#20230623.1 • added SDE09 with new item and corresponding artifacts ↳ Manually triggered for atlrn09
GenerateBaseline	#20230623.2 • Changed method as a result of review process ↳ Manually triggered for atlrn08
DeleteInnovator	#20230504.1 • fix floating issue with build agents ↳ Manually triggered for development

4. Click **Run Pipeline** in the top right hand.

Description	Stages	Last run
#20230623.2 • Changed method as a result of review process ↳ Manually triggered for atlrn08 31bee7a	-	Jun 23 21m 30s
#20230623.1 • added SDE09 with new item and corresponding arti... ↳ Manually triggered for atlrn09 3f3f19b6	-	Jun 23 21m 40s
#20230504.1 • fix floating issue with build agents ↳ Manually triggered for 1.0.202305041 877d905b	-	May 4 23m 4s

5. In the **Run Pipeline** dialog, enter the following details:
 - **Branch/tag:** Select the branch/Tag created in the above section
 - **Advance options:** default settings
 - **Enable system diagnostics:** unchecked

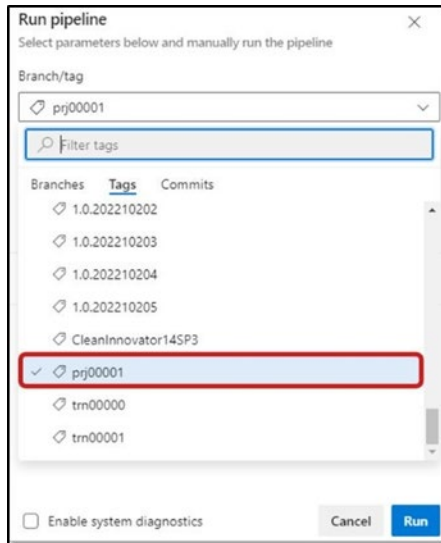

Note that the pipeline must be executed by selecting tags only.

6. Click **Run**.
7. The pipeline is queued by the system, and the progress can be by clicking on the **Stages and Jobs** tabs in the pipeline run page.
8. The new baseline will be uploaded to the storage account and "Baselines" artifact feed (Artifacts > Baselines dropdown).

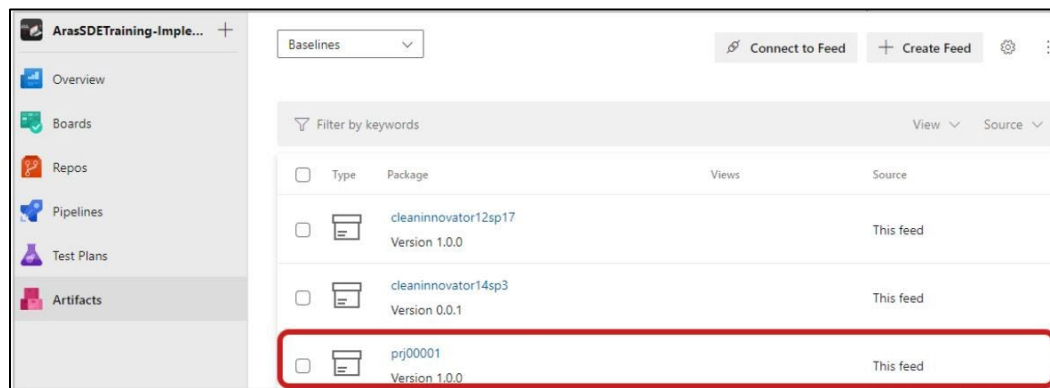

7.3 Delete Aras Innovator from SIT Environment

The SIT environment provides resources for a maximum of 10 Aras Innovator test instances. Aras recommends keeping the number of test instances at about 3-5. To prevent potential performance degradation, the project team should retain the latest test instances while removing older ones. The DeleteInnovator pipeline is used to delete test instances by providing the instance name (low case) and identifying the build.

After approximately 30 days, the system will automatically delete a build.

The following steps outline the process of deleting the Aras Innovator from SIT Environment:

1. Navigate to <https://dev.azure.com/{organization}/{project}>.
2. Click **Overview** and select **Wiki** page.



3. Expand **Environment Information** and select **SIT**.

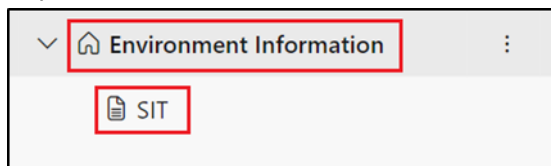

The list of available instances appears.

A screenshot of the 'SIT' environment page. The page title is 'SIT' and it shows 'Release Portal Monday'. Below this is a table with two columns: 'Name' and 'Creation Date'. The table contains six rows of instance data.

Name	Creation Date
SIT-1-0-202207054	05-Jul-2022 11:43
SIT-1-0-202207062	06-Jul-2022 10:13
SIT-1-0-202207064	06-Jul-2022 01:18
SIT-1-0-202207081	08-Jul-2022 08:44
SIT-1-0-202207112	11-Jul-2022 11:13
SIT-1-0-202207116	11-Jul-2022 03:34

4. Copy the required instance.

5. Navigate to **Pipelines** and select **DeleteInnovator** pipeline.

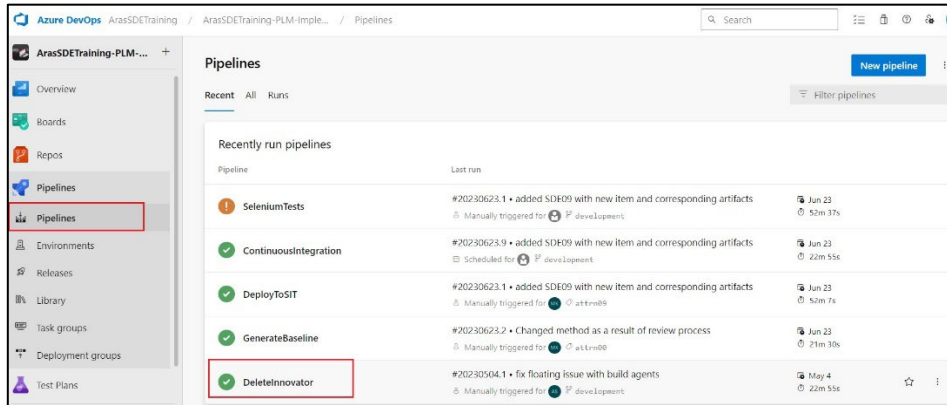

6. Click **Run Pipeline**.
7. In the Innovator instance name to delete field, paste the SIT instance which is copied in step 4.
8. Select Resources and click **ContinuousIntegration[Delete Innovator]**.

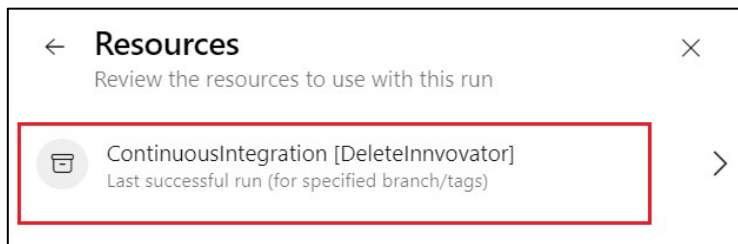

9. Select the correct build. The build name ends with a timestamp `yyyymmdd##`. In the corresponding build, the build number is separated from the date by a dot.

Note: The timestamp of SIT instance should match the timestamp of the build.

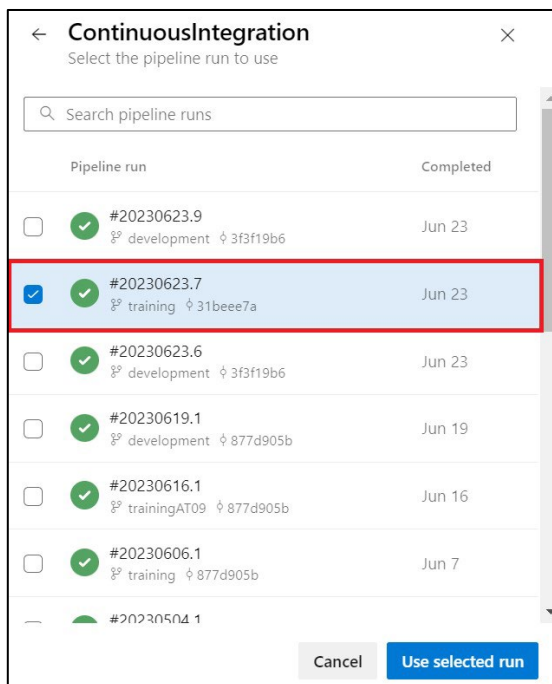

10. Click **Use selected run**.

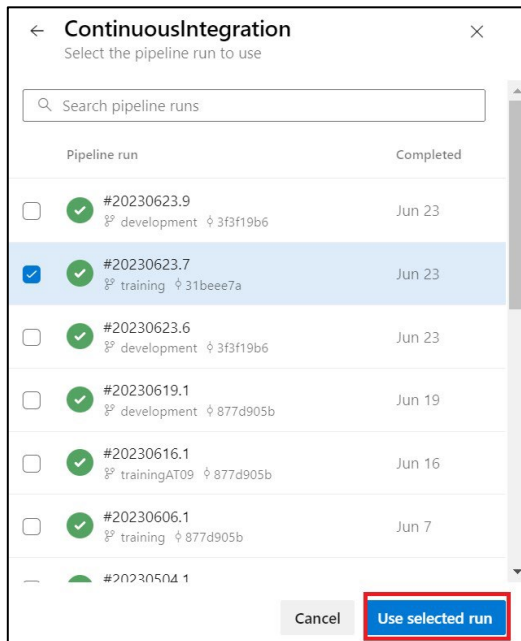

11. Select **Variables** enter the value in the Update Variable dialog box. Set the variable in lowercase "sit" and click **Update**.

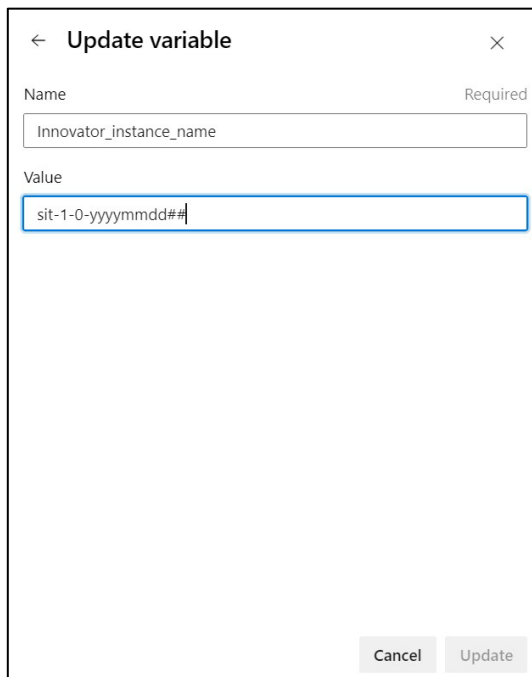

12. Navigate back to **Run Pipeline** pane and click **run**.

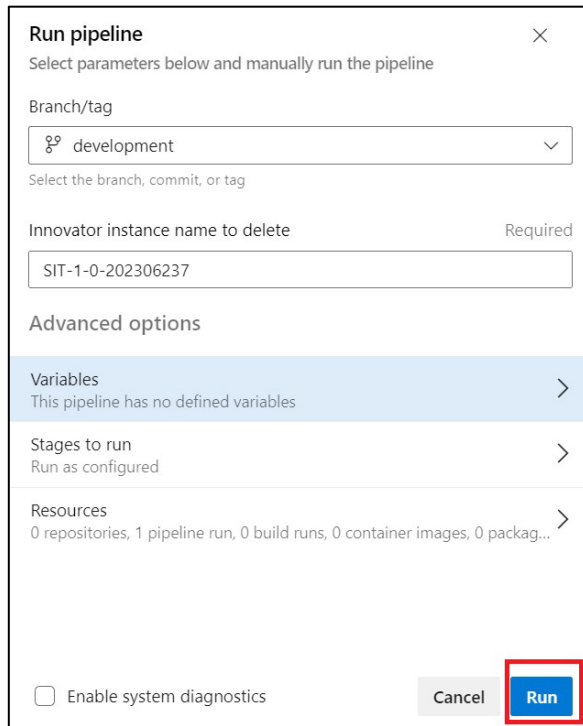

The image shows a 'Run pipeline' dialog box with the following elements:

- Run pipeline** (title bar with a close button)
- Subtitle: *Select parameters below and manually run the pipeline*
- Branch/tag**: A dropdown menu showing 'development' with a search icon and a downward arrow. Below it is the text 'Select the branch, commit, or tag'.
- Innovator instance name to delete**: A text input field containing 'SIT-1-0-202306237'. To its right is the label 'Required'.
- Advanced options**: A section header.
- Variables**: A blue header with a right-pointing arrow. Below it: 'This pipeline has no defined variables'.
- Stages to run**: A header with a right-pointing arrow. Below it: 'Run as configured'.
- Resources**: A header with a right-pointing arrow. Below it: '0 repositories, 1 pipeline run, 0 build runs, 0 container images, 0 packag...'
- At the bottom left: Enable system diagnostics
- At the bottom right: 'Cancel' and 'Run' buttons. The 'Run' button is highlighted with a red square.

13. If the build has expired, select the oldest green build.

7.4 Delta deployment to production and non-production environments

Delta Deployment functionality is an Aras DevOps feature available for Aras Enterprise customers working with containerized deployments.

Delta deployment provides a possibility to deploy changes from Work repository on top of existing Innovator deployment. The database of the target Innovator deployment will not be dropped and restored. The customization changes will be deployed on top of the existing database.

Users will have the capability to utilize this feature in order to update the existing instance in SIT (System Integration Testing), UAT (User Acceptance Testing), Staging or Production environments

The following steps outline the high-level process of delta deployment:

1. Determine the Innovator Release name which user wants to update.
2. Determine deployment package version with customization which user wants to deploy to the previously deployed Innovator.

Users can either use:

The Build Number of CI pipeline corresponding to the version of the customization which user wants to deploy

or

The name and the version of the Deployment package.

3. Run Deploy pipeline with Update strategy.

7.4.1 Redeploy UAT deployment on Existing Database

The below sections outline the process of redeploying UAT deployments on top of the existing database.

7.4.1.1 Determine the Innovator Deployment name

The following steps outline the process of determine the Aras Innovator release name for the deployed Aras Innovator Instance which user wants to update:

1. On Azure DevOps, click **Wiki**.

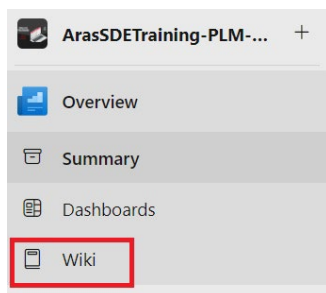

- Under **Environment Information** section, select **UAT**.
Copy the release name under **Name** tab in **UAT** section.

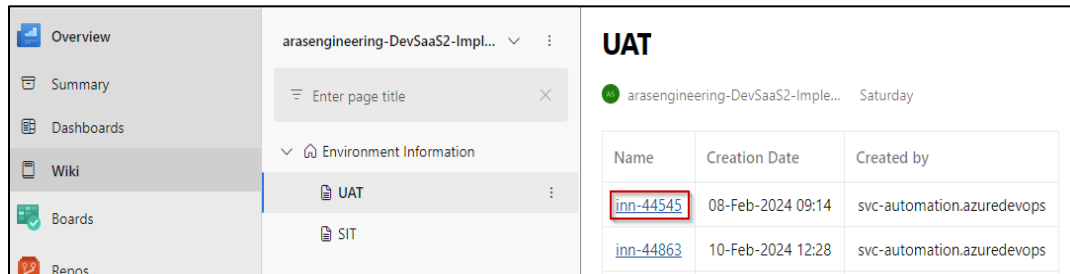

Please copy the name, it will be useful during the deploy pipeline.

7.4.1.2 Determine Deployment Package

Determine deployment package version with customization which user wants to deploy to the previously deployed Innovator. This can be done in following two ways:

- Obtain the Build Number of the CI pipeline corresponding to the version of the customization user wants to deploy.
- Obtain the name and the version of the Deployment package name.

CI Pipeline build number

The following steps outline the process of obtaining the build number of the CI pipeline that was executed on commit intended for update:

- In Azure DevOps, go to **Pipelines**.

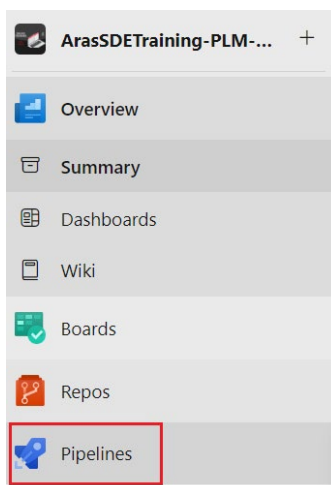

- Select **ContinuousIntegration** and select the necessary CI pipeline.

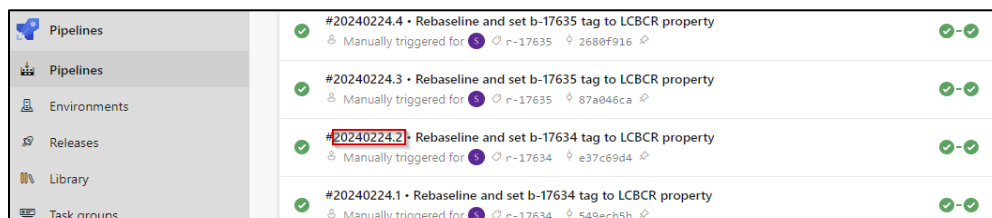

Please copy the build number, it will be useful during deploy pipeline.

Deployment Package Name and Deployment Package Version

Please find stable version of deployment package name and deployment package version. It can be found in Continuous Integration pipeline logs. Open “**Publish Nuget package to {ProjectName}-Artifacts feed**” and find line similar to the following screenshot:

✓ Import i...	1m 52s
✓ Run Com...	4m 13s
✓ Package Upl...	11s
✓ Copy Test Res...	1s
✓ Copy Nuget p...	1s
✓ Publish Nuge...	13s
✓ Publish Auto...	2s
✓ Post-job: Ch...	<1s

```

1 Starting: Publish Nuget package to DevSaaS2-Artifacts feed
2 =====
3 Task      : Universal packages
4 Description : Download or publish Universal Packages
5 Version   : 0.231.0
6 Author    : Microsoft Corporation
7 Help      : https://docs.microsoft.com/azure/devops/pipelines/tasks/pa
8 =====
9 Downloading: https://@t3vsblobprodcus362.vsblob.vsassets.io/artifacttool/
10 Caching tool: ArtifactTool 0.2.304 x64
11 Publishing package: nika.master, version: 1.0.202402275-n2 using feed id:
12 C:\a\_tool\ArtifactTool\0.2.304\x64\ArtifactTool.exe universal publish --t
13 {"@t":"2024-02-27T12:07:15.2345047Z","@m":"ApplicationInsightsTelemetrySer

```

For example:

Publishing package: custom_deployment_package_name, version: 1.0.202402263-b-17641

7.4.1.3 Run Deploy pipeline with Update strategy

The following steps outline the process of running the deploy pipeline with update strategy:

1. Go to **Deploy** Innovator pipeline.
2. Select **Run Pipeline**.
3. Select appropriate **Branch/tag**.
4. Choose **Deployment type**.

Run pipeline ✕

Select parameters below and manually run the pipeline

Branch/tag
 ▼
Select the branch, commit, or tag

Deployment type:
 ▼

Deploy timeout in minutes

Optional variable group name: (Default one is used if none provided)

Custom config variable group name: (Default one is used if none provided)

Advanced options

Variables
8 variables defined ➤

Stages to run
Run as configured ➤

Resources
Use latest version of all resources ➤

Enable system diagnostics Cancel Run

5. To choose the required Deployment Package, use one of options below:

- Click Resources in **Advanced** options. Search for correct CI pipeline with the code changes that needs to be applied to the Innovator which is obtained in section **Determine Deployment Package** and then click **Use selected run** to apply.

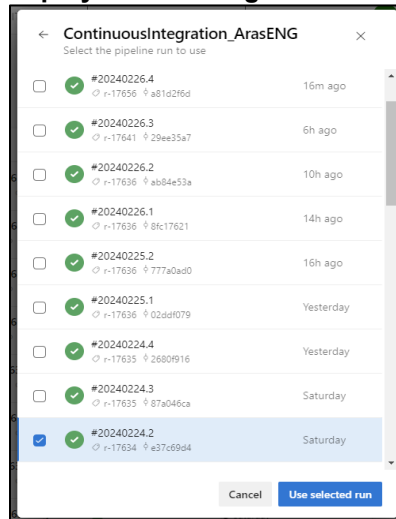

- Click **Variables** in **Advanced** options and specify **deployment_package_name** and **deployment_package_version** with values which is obtained in section **Determine Deployment Package**.

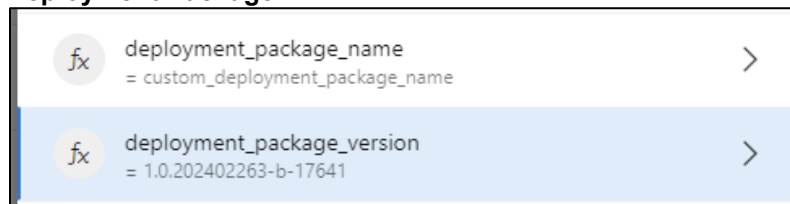

6. Click **Variables** in **Advanced** options.

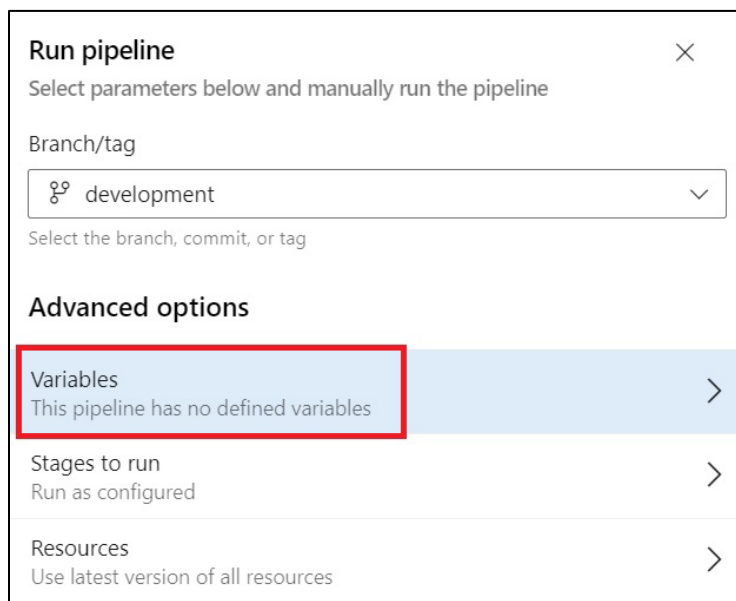

7. Add the following Variables:

Name	Value
personal_access_token	Enter the PAT token in case of deployment to UAT, Staging or PROD
innovator_release_name	Enter release name of the currently deployed Innovator that needs to be updated
setup_instance_strategy	Enter "Update"
cluster_index	Enter a cluster identification value for deployment. This is especially helpful when deploying multiple Vaults across different geographical clusters. Typically, '01' suffices as the default value
install_conversion_server	The default value is 'true'

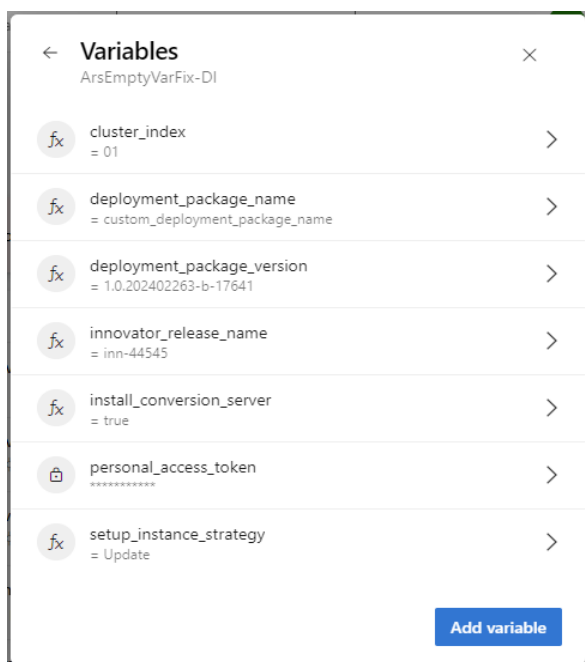

The **setup_instance_strategy** can have the following values:

Deploy – enables to create a new deployment. This is the default value of this variable for deployments to SIT environment.

Update – enables to update existing deployment. This is the default value of this variable for deployments to UAT, Staging and PROD environments.

RollingUpdate – this is an update type that should be used when only CodeTree changes should be applied. The pipeline will fail in case of any changes in AML-packages.

8. Click **Run**.

The outcome of this operation will deploy the new changes onto the existing database and Innovator instance, matching the **innovator_release_name** with **setup_instance_strategy** set to **Update**.

8 Using Transformations

8.1 Transformation Overview

A transformation is a mechanism to update configuration files such as XML or JSON files of Aras Innovator using a special syntax. Since all config files are XML or JSON, then XDT or JDT transformation respectively is used.

This procedure is intended to be idempotent, implying that repeated application of the transformation to a specific configuration file (like those of Aras Innovator) should consistently result in the same state as achieved immediately after the initial transformation application.

Idempotence ensures that regardless of the number of times a transformation is applied to a specific configuration file, the outcome remains consistent and predictable, thus eliminating the need to manage any delta changes.

8.2 Type of Transformation

There are two following types of transformation:

1. **XMI Document Transformation (XDT)**: This enables transforming XML file.
2. **JSON Document Transforms (JDT)**: This enables transforming JSON files.

8.3 The Purpose of Transformation

Only the specific configuration files are updated rather than a complete overwrite of the content.

This approach facilitates modifications only in the required sections of the configuration, ensuring that all other settings remain unaffected.

It is the responsibility of the developer to create such transformation that might be applied many times to the config file. It should give the same result as after the first application of the transformation.

The standard Aras Innovator platform deployment only contains the information below in the conversion server configuration file.

```
<?xml version="1.0" encoding="utf-8"?>
<configuration>
<configSections>
<section name="oauth" type="Aras.OAuth.Configuration.OAuthSection,
Aras.OAuth.Configuration" />
</configSections>
<oauth configSource="OAuth.config" />
</configuration>
```

To activate conversion per the requirements and entitlements of a project, the project team must provide information in the transformation file.

8.4 Utilizing Transformation

If any update is required in configuration file, a file with an identical name should be created within the "TransformationsOfConfigFiles" directory, using relative path of file.

Idempotence isn't provided out of the box; utilization of specific transformation actions is required.

In the XDT framework, these operations are signified by the suffix 'IfMissing' (such as 'InsertIfMissing'). Conversely, in JDT, the 'Merge' action is the most suitable for this purpose. Therefore, it's up to the developer to ensure their transformations are idempotent.

8.4.1 Example 1: XML Document Transformation (XDT)

Consider a scenario where a user needs to modify the file "OAuthServer\Web.config" and wants to add an attribute to the "oauth" tag in which the value of the "configSource" attribute is equal to "OAuth.config".

1. Create a file "OAuthServer\Web.config" in TransformationsOfConfigFiles folder according to XDT rules.
2. Fill it in according to the XDT rules.
3. Commit the changes.
4. Transformation is reflected in OAuthServer\Web.config after next deployment. Next time the config file should give the same result as after first apply of the transformation.
5. Sample XML transformation:

```

` ``xml
<?xml version="1.0"?>
<configuration xmlns:xdt="http://schemas.microsoft.com/XML-Document-
Transform">
    <oauth configSource="OAuth.config" yourNewAttribute="value"
xdt:Transform="SetAttributes" xdt:Locator="Match(configSource)" />
</configuration>

```

- For XDT Documentation, please visit - [https://learn.microsoft.com/en-us/previous-versions/aspnet/dd465326\(v=vs.110\)](https://learn.microsoft.com/en-us/previous-versions/aspnet/dd465326(v=vs.110))
- For Web.config Transformation Syntax for Web Project Deployment Using Visual Studio, please visit - <https://learn.microsoft.com/en-us/aspnet/core/host-and-deploy/iis/transform-webconfig?view=aspnetcore-5.0>

8.4.2 Example 2: JSON Document Transformation (JDT)

Consider a scenario where a user needs to add a new plugin to “OAuthServer\OAuthServer.Plugins.json”.

1. Create a file “**OAuthServer\OAuthServer.Plugins.json**” in directory “TransformationsOfConfigFiles” according to JDT rules.
2. Fill it in according to the JDT rules;
3. Commit the changes.

Transformation will reflect in **OAuthServer\Web.config** after next deployment. Next time config file should give the same result as after first apply of the transformation.

Sample JDT Transformation:

```
```json
{
 "@jdt.merge": {
 "@jdt.path": "$['OAuthServer.Plugins']",
 "@jdt.value": [
 {
 "Name": "New.Aras.Plugin",
 "Enabled": true
 }
]
 }
}
```
```

- For JDT documentation, please visit- <https://github.com/microsoft/json-document-transforms/wiki>)

8.5 Ignore Configuration Files Transformation

The need usually arises when the user does not need transformation, or any validation error occurred at the time of implementation.

For ignore transformation add a line with file location (relative path) in the following file: “TransformationsOfConfigFiles\transformations.ignore”.

For more details and syntax of transformation, please refer below file in cloned repository: TransformationsOfConfigFiles\Readme.md.

8.6 Environment Specific configuration

Environment specific configuration functionality is an Aras DevOps feature available for Aras Enterprise customers working with containerized deployments.

This functionality enables customers to deploy Aras Innovator instances from one single Git branch to different environments (System Integration Testing, User Acceptance Testing, Staging, Production) and introduce variability in the configuration. The configuration transformations use variables instead of fixed values. Customizable Azure DevOps variable groups define variable values.

Aras Enterprise customers use this feature to manage variability in Aras Innovator configuration files on different environments without having to manage separate branches for each environment.

The following steps outline the high-level process of environment specific configuration:

1. Add a transformation that adds a custom variable to a configuration file.
2. Add the custom variable to the environment specific variable group.
3. Run CI pipeline to add the transformation to the deployment package.
4. Run Deploy pipeline with appropriate variable group.

8.6.1 Example: Define an environment specific login screen

This section illustrates an example on how to create two SIT deployments with different configurations. Different login screen background images will be created for these deployments.

The following steps outline the process of creating different login screen background images:

1. Add a transformation that adds custom variable to a configuration file. Following is the example of transformation that sets `imagePath` value in `BackgroundImageUrl` property. This should be added to `TransformationsOfConfigFiles/OAuthServer/OAuthServer.config` folder:

```
<?xml version="1.0" encoding="utf-8"?>
<configuration xmlns:xdt="http://schemas.microsoft.com/XML-Document-Transform">
  <appSettings>
    <add key="BackgroundImageUrl" xdt:Locator="Match(key)"
xdt:Transform="SetAttributes(value)" value="{imagePath}"/>
  </appSettings>
</configuration>
```

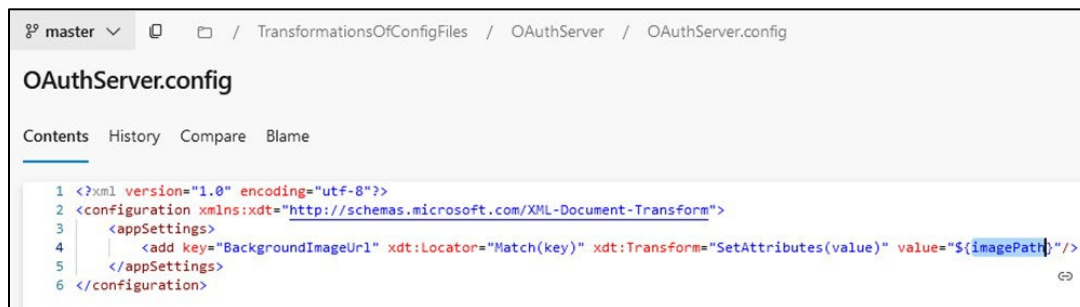

The screenshot shows a code editor window with the following content:

```
master / TransformationsOfConfigFiles / OAuthServer / OAuthServer.config
OAuthServer.config
Contents History Compare Blame
1 <?xml version="1.0" encoding="utf-8"?>
2 <configuration xmlns:xdt="http://schemas.microsoft.com/XML-Document-Transform">
3   <appSettings>
4     <add key="BackgroundImageUrl" xdt:Locator="Match(key)" xdt:Transform="SetAttributes(value)" value="{imagePath}"/>
5   </appSettings>
6 </configuration>
```

New background images should be added to **CodeTree/OAuthServer/wwwroot/images** folder.

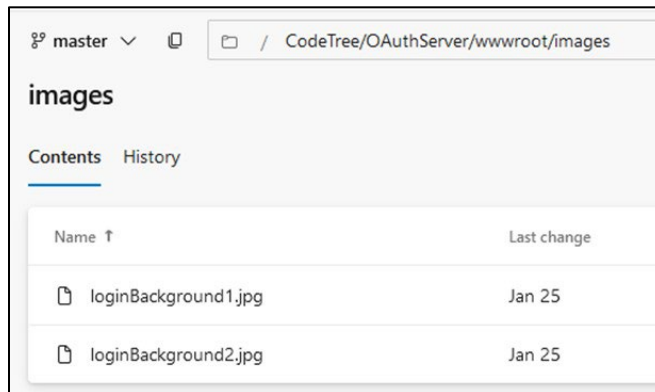

2. Commit the transformation and images and push to Work repository in Azure DevOps.
3. Next, set the values for variables for each Environment. By default, the project has 5 variable groups defined for custom configurations as follows:

Pipelines	fx CustomConfigValues-CI
Pipelines	fx CustomConfigValues-PROD
Environments	fx CustomConfigValues-SIT
Releases	fx CustomConfigValues-STG
Library	fx CustomConfigValues-UAT

4. Select **CustomConfigValues-SIT** variable group.

Pipelines	fx CustomConfigValues-CI
Pipelines	fx CustomConfigValues-PROD
Environments	fx CustomConfigValues-SIT
Releases	fx CustomConfigValues-STG
Library	fx CustomConfigValues-UAT

5. Add a variable with the name `imagePath` and the value is `~/images/loginBackground1.jpg`.

Library > CustomConfigValues-SIT

Variable group | Save | Clone | Security | Pipeline permissions | Approvals and checks | Help

Properties

Variable group name
CustomConfigValues-SIT

Description
This Variable Group was created automatically and is used to define environment-specific variables

Link secrets from an Azure key vault as variables ⓘ

Variables

Name ↑	Value
imagePath	~/images/loginBackground1.jpg

+ Add

6. Run continuous integration pipeline.
7. Run deploy pipeline with default parameters using continuous integration from step 6 as a Resource.

This pipeline creates a new deployment using CustomConfigValues-SIT variable group for custom configuration. The BackgroundImageUrl value will be set to the value of imagePath from the variable group as it is defined in the transformation.

Environment specific variables from CustomConfigValues-SIT variable group are always applied by Deploy Innovator pipelines during initial deploy or redeployment.

Run pipeline ✕

Select parameters below and manually run the pipeline

Branch/tag
 ▼
Select the branch, commit, or tag

Deployment type:
 ▼

Deploy timeout in minutes

Optional variable group name: (Default one is used if none provided)

Custom config variable group name: (Default one is used if none provided)

Advanced options

Variables
 8 variables defined >

Stages to run
 Run as configured >

Resources
 Use latest version of all resources >

Enable system diagnostics

8. Visit the deployed Innovator to verify the change in the background image on the login page.

To create another deployment using another configuration of the image path, modify the default variable group (CustomConfigValues-SIT) or create a new variable group for the second deployment.

Following is the example of deployment with a new variable group with 'my-custom-group' name:

- In Azure DevOps, select **Library** and click **+ Variable group** to create a new variable group.
- Set name to **'my-custom-group'**.

- Add **imagePath** variable and set path to the second image as the value (**~/images/loginBackground2.jpg**).

Library > my-custom-group

Variable group | Save | Clone | Security | Pipeline permissions | Approvals and checks | Help

Properties

Variable group name: my-custom-group

Description: [Empty text area]

Link secrets from an Azure key vault as variables

Variables

Name ↑	Value
imagePath	~/images/loginBackground2.jpg

+ Add

- Run deploy pipeline again with the new variable group name set as parameter.

Run pipeline [Close]

Select parameters below and manually run the pipeline

Branch/tag: master

Deployment type: SIT

Deploy timeout in minutes: 180

Optional variable group name: -

Custom config variable group name: **my-custom-group**

Advanced options

Variables: 8 variables defined

Stages to run: Run as configured

Resources: Use latest version of all resources

Enable system diagnostics

Cancel Run

- Go to the deployed Innovator to check that the background image on login page has changed.

8.6.2 Default variable groups

By default, there are 5 auto-generated variable groups.

1. The CustomConfigValues-CI variable group is the default group for CI pipeline.
2. The CustomConfigValues-SIT, CustomConfigValues-UAT, CustomConfigValues-STG, CustomConfigValues-PROD groups are used by default when running Deploy Innovator pipeline to SIT, UAT, Staging or Production correspondingly.

Also, custom variable group can be created and pass it as a parameter:

Custom config variable group name: (Default one is used if none provided)

8.6.3 Adding a secret

To use secret as an environment specific variable you should go to variable group and mark variable as secret.

The following steps outline the process of marking a variable as secret:

1. From Azure DevOps, go to **Library**.
2. Select a variable group.
3. In the **Variables** section, mark a variable as secret by clicking on **Change variable type to plain text**.

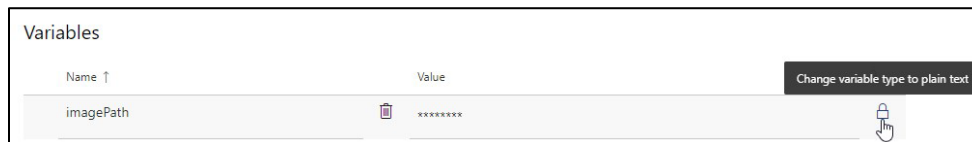

As secrets are encrypted variables with higher protection level, user need to declare them in the `env_vars` section of `TransformationsOfConfigFiles/environment-specific-secrets.yaml` file.

This will allow reading secrets and passing them, along with other environment-specific variables, to deployments during the Deploy Innovator or Continuous Integration pipelines.

If secret is not defined in `environment-specific-secrets.yaml` file it will be read as an empty variable, so please be careful.

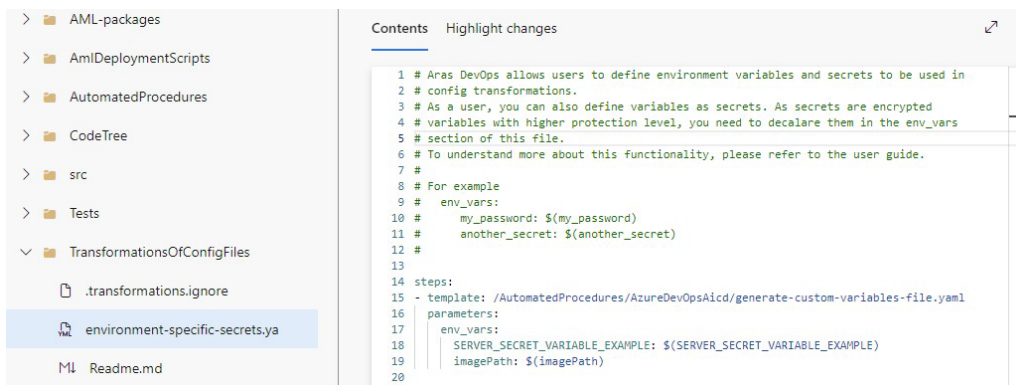

8.6.4 Variables naming and scope

By default, a variable can have any name and will be common for all servers, like `imagePath` etc.

It is possible to specify variable for one specific server. If user wants to make sure that variable will be used on one specific server (OAuth server or conversion server), user should use prefix in variable name; for example, **oauthimagePath**. The possible prefixes are oauth, client, server, conversion, agent, vault.

8.6.5 Restrictions

The environment specific configuration functionality has several following restrictions:

1. The length of a variable value in Azure DevOps is limited to 4096 symbols.
2. The total length of the variables file that is created by converting variables and values stored in variable group, must be less than 25600 characters to fit key vault secret length. This limitation appeared because each deployment pipeline creates a variables file based on the variable group and saves this file into the Azure Key Vault to provide possibility to audit history and rollback values.

9 External authentication

External authentication functionality is an Aras DevOps feature available for Aras Enterprise customers working with containerized deployments.

This functionality enables customers to configure Aras Innovator instances to allow single sign on using external identity provider.

Each external authentication consists of two steps:

1. External authentication in external identity provider.
2. Process the result of external identity provider login by mapping an external user to the Aras Innovator user. Each external authentication has its own user format, so it is important that the user mapper can handle any user format. The Generic User Mapper plugin can flexibly configure mapping an external user to an Aras Innovator user for multiple authentication types.

For single sign on using external authentication to Aras Innovator, it is necessary to configure authentication plugins for each step.

The following steps outline the high-level process of external authentication configuration:

1. Configure external identity provider (e.g. add application registry).
2. Add transformation for external authentication plugin (e.g. `Aras.OAuth.Server.Plugins.Saml2Authentication` plugin) and for user mapper plugin (e.g. using `Aras.OAuth.Server.Plugins.GenericUserMapper` plugin).
3. Run CI pipeline and Deploy pipeline.
4. Create user that corresponds to mapping.
5. Configure access to external identity provider (e.g. DNS settings).

9.1 Aras Innovator External Authentication using SAML 2.0 Authentication

Aras Innovator provides the flexibility of providing various options to administrators when controlling the maintenance of user logins to Aras Innovator. One method is the use of the SAML 2.0 Authentication Plugin which provides a way to log into Aras Innovator using the SAML 2.0 authentication protocol.

To view the documentation of the SAML 2.0 protocol please go to: <https://www.oasis-open.org/standards/#samlv2.0>.

SAML 2.0 is a protocol for exchanging authentication and authorization data between security domains. The protocol is XML-based and uses security tokens containing assertions to pass information about a principal (usually an end user) between a SAML authority, called an Identity Provider, and a SAML consumer, called a Service Provider. SAML 2.0 enables web-based, cross-domain single sign-on (SSO), which helps to reduce the administrative overhead of distributing multiple authentication tokens to the user.

The Aras Innovator logon may be customized using the SAML 2.0 Authentication Plugin described in this section. This plugin provides a way to use external identity providers by the SAML 2.0 protocol for Aras Innovator. The customization requires changes in the OAuth server configuration to enable the SAML 2.0 authentication plugin.

The SAML 2.0 protocol includes the following:

- An identity provider authenticates users and provides the service provider with an authentication assertion, if it is successful.
- A service provider relies on the identity provider to authenticate users. The OAuth server acts as a service provider in our system.

The following steps outline the high-level process of SAML2 authentication configuration:

1. Configure external identity provider (e.g. add application registry).
2. Add transformation for Aras.OAuth.Server.Plugins.Saml2Authentication plugin and for Aras.OAuth.Server.Plugins.GenericUserMapper plugin.
3. Run CI pipeline and Deploy pipeline.
4. Create user that corresponds to mapping.
5. Configure access to external identity provider (e.g. DNS settings).

9.1.1 Example: Setup of Aras Innovator SAML 2.0 Authentication with Azure as Identity provider

This section illustrates an example on how to configure deployment to login in to Aras Innovator using external user using SAML2 protocol. Login using google account will be configured for this deployment.

The below sections outline the process of configuring external authentication.

9.1.1.1 Configure external identity provider (e.g. add app registry)

Please refer to the manual for more details: <https://support.google.com/a/answer/6087519>.

The following steps outline the process of configuring the external identity provider:

1. Ensure to have a Google admin account on admin.google.com. The e-mail should be of the domain which will be used as Service provider (Innovator). For example, if the instance is `https://domain.com/instance/`, then the e-mail should be `username@domain.com`.
2. Log into <https://admin.google.com/>.
3. From the left pane, Go to **Apps** and click **Web and mobile apps**.
4. Click **Add app**, then select **Add custom SAML App**.

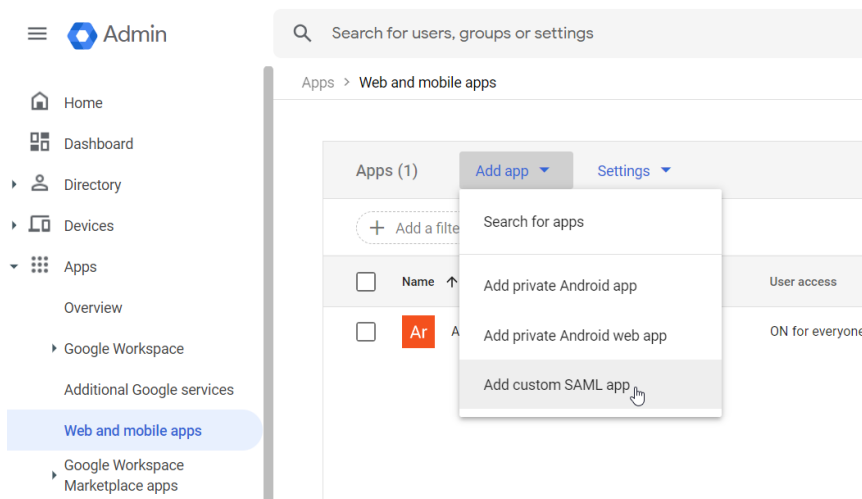

5. Fill in the **App** details.

The screenshot shows a form titled "Add custom SAML app". Under the "App details" section, the "App name" field is filled with "TestApp". The "Description" field is empty. Below the description is the "App icon" section, which includes a blue circular icon with a camera symbol and the text "Attach an app icon. Maximum upload file size: 4 MB". At the bottom right of the form, there are "CANCEL" and "CONTINUE" buttons.

6. Click **Continue**.

7. Download metadata on the computer and copy **EntityId** (download signing certificate, if required).

The screenshot shows the "Add custom SAML app" form with "Option 1: Download IDP metadata" selected. The "DOWNLOAD METADATA" button is visible. Below this, there is an "OR" separator. Under "Option 2: Copy the SSO URL, entity ID, and certificate", the "SSO URL" field contains "https://accounts.google.com/o/saml2/okp?id=D02c0u9vx". The "Entity ID" field contains "https://accounts.google.com/o/saml2/okp?id=C02c0u9vx". The "Certificate" field contains a long string of characters: "Google_2029-5-5-33622_SAML2_0" followed by a multi-line certificate block starting with "-----BEGIN CERTIFICATE-----". At the bottom, there are "BACK", "CANCEL", and "CONTINUE" buttons.

8. Click **Continue**.

9. Enter **ACS URL** for the instance. For example, `https://{OAuthServerURL}/Saml2-AzureAD/Acs`.

10. Enter **Entity ID** for the instance. For example, <https://{{OAuthServerURL}}/Saml2-AzureAD/>.

Service provider details
To configure single sign on, add service provider details such as ACS URL and entity ID. [Learn more](#)

ACS URL
`https://{{OAuthServerURL}}/Saml2-AzureAD/Acs`

Entity ID
`https://{{OAuthServerURL}}/Saml2-AzureAD/`

Start URL (optional)

Signed response

Name ID
Defines the naming format supported by the identity provider. [Learn more](#)

Name ID format
EMAIL

Name ID
Basic Information > Primary email

BACK CANCEL CONTINUE

11. Click **Save**.

12. Click **Apps**, and click on **Web and mobile apps** and check if user access is 'ON for everyone'.

SAML

Te TestApp

TEST SAML LOGIN
DOWNLOAD METADATA
EDIT DETAILS
DELETE APP

User access
To make the managed app available to select users, choose a group or organizational unit. [Learn more](#)
[View details](#)
ON for everyone

Service provider details

Certificate	ACS URL	Entity ID
Google_2029-5-5-33622_SAML2_0 (Expires May 5, 2029)	https://devsaas214-nprd-01.gcs.arasqa.com/instance/OAuthServer/Saml2-AzureAD/ACS	https://devsaas214-nprd-01.gcs.arasqa.com/instance/OAuthServer/Saml2-AzureAD/

SAML attribute mapping
SAML attribute mapping isn't configured
Map Google directory user profile fields to SAML service provider attributes.
[Configure SAML attribute mapping](#)

13. Click **Add Mapping** and change mapping options to receive correct claim after login to google.

Apps > Web and mobile apps > Aras Cloud > Attribute mapping

SAML

Ar Aras Cloud

TEST SAML LOGIN
DOWNLOAD METADATA
EDIT DETAILS
DELETE APP

SAML attribute mapping

Attributes
Add and select user fields in Google Directory, then map them to service provider attributes. Attributes marked with * are mandatory. [Learn more](#)

Google Directory attributes	App attributes
Basic Information > Primary email	nameidentifier

ADD MAPPING

Group membership (optional)
Group membership information can be sent in the SAML response if the user belongs to any of the groups you add here.

Google groups	App attribute
Search for a group	Groups

CANCEL SAVE

14. Go to **Home** tab and in **Users** section assign users to log in.

Please refer to the following link to Microsoft about configuration Azure as identity provider:
<https://learn.microsoft.com/en-us/entra/identity/enterprise-apps/add-application-portal-setup-SSO>.

9.1.1.2 Add transformation for Aras.OAuth.Server.Plugins.Saml2Authentication plugin and for Aras.OAuth.Server.Plugins.GenericUserMapper plugin.

In order to turn on Aras Innovator SAML 2.0 Authentication, update OAuthServer.Plugins.json settings with Transformation mechanism using jdt transformation.

Find more information in readme file in **TransformationsOfConfigFiles** folder of the .Work repository in Azure DevOps.

The values of the required parameters can be obtained from the **Configure external identity provider** section.

You need to add OAuthServer.Plugins.json file to TransformationsOfConfigFiles/OAuthServer of the repository.

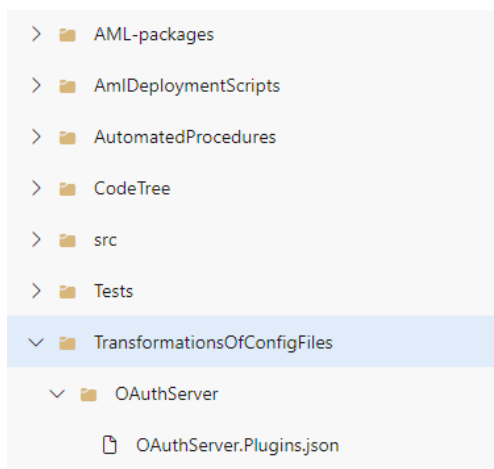

The file should contain jdt transformation of configuration of Aras.OAuth.Server.Plugins.Saml2Authentication and Aras.OAuth.Server.Plugins.GenericUserMapper plugins.

Here is an example of jdt transformation using OAuthServer.Plugins.json file:

```
{
  "@jdt.merge": {
    "@jdt.path": "$,['OAuthServer.Plugins']",
    "@jdt.value": [
      {
        "Name": "Aras.OAuth.Server.Plugins.Saml2Authentication",
        "Enabled": true,
        "Options": [
          {
            "AuthenticationType": "Saml2-AzureAD",
            "DisplayName": "Saml2 Google",
```

```

        "ServiceProviderOptions": {
            "EntityId": "https://{OAuthServerURL}/Saml2-
AzureAD/"
        },
        "IdentityProviderOptions": {
            "EntityId":
"https://accounts.google.com/o/saml2?idpid=C02c0u5vx",
            "MetadataSource": "MetadataLocation",
            "MetadataLocation":
"/app/sit_GoogleIDPMetadata.xml"
        }
    ]
},
{
    "Name": "Aras.OAuth.Server.Plugins.GenericUserMapper",
    "Enabled": true,
    "Options": [
        {
            "AuthenticationType": "Saml2-AzureAD",
            "InnovatorUserNameFormat": "{username}",
            "ClaimActions": [
                {
                    "ActionName": "CreateFrom",
                    "ActionOptions": {
                        "ClaimType": "username",
                        "SourceClaimType":
"http://schemas.xmlsoap.org/ws/2005/05/identity/claims/nameidentifie
r",
                        "ReplacePattern": "@.+",
                        "Replacement": "",
                        "PatternOptions": [ "IgnoreCase",
"Singleline" ]
                    }
                },
                {
                    "ActionName": "Validate",
                    "ActionOptions": {
                        "ClaimType": "username",

```

9.1.1.4 Create user for Corresponding Mapping

Login to Aras Innovator instance as an administrator and create a user according to the mapping strategy. For example:

Login name will be username of the e-mail address which is a prefix of @.

User Name ☆ 🚩

Edit 🔄 🔄 🔄 📄 📄 📄 ⋮

User

Login Name username	First Name User	Last Name Name	Company Name
Password ***	Email username@domain.com	Telephone	Mail Stop
Confirm Password ***	Fax	Home Phone	Picture
Logon Enabled <input checked="" type="checkbox"/>	Cell	Pager	
Starting Page	Employee #	Manager	
Default Vault Default	Working Directory		

9.1.1.5 Configure access to external identity provider (e.g. DNS settings)

If Google requests domain verification, please follow the provided instructions.

The following steps outline the process of configuring the communication between google and the domain:

1. Open domain settings in admin.google.com, and fill in the required properties. See Configure external identity provider section for more details.
2. Go to Azure portal DNS settings and follow the google instruction about adding MX records for domain to make domain verified. Two records were added to DNS settings.

devsaas214-nprd-01 ...
gcs.arasqa.com

Save Discard Delete Users Metadata

devsaas214-nprd-01.gcs.arasqa.com

Type
MX

TTL * 1 TTL unit Hours

Preference	Mail exchange
1	SMTP.GOOGLE.COM
15	VNGALAG4QJPXSCZEROPRTJMABYEWK424ZVBRKMNH7EKO6A53ZQ.MX-VERIFICATIO...
	mail.contoso.com

3. Continue verification in admin.google.com.

After following all above steps, the login should be successful. Please refer to SAML2 Authentication Plugin Configuration section of this document for more details.

9.2 Configuring Secure Files

The following steps outline the high-level process of using the certificates during deployment:

1. Upload a certificate to secure file storage.
2. Configure file permissions for pipeline.
3. Add a transformation with link to certificate.

Please ensure that the file names should start with a prefix depending on the environment this file will be used in. The file names can start from SIT, UAT, STG or PROD. Files should have CI prefix to be used in continuous integration pipeline.

For example: SIT-SAML.pem.

Files that do not start with allowed prefixes will be ignored.

9.2.1 Upload a certificate as a secure file

The following steps outline the process of uploading a certificate as a secure file:

1. Upload a certificate as a secure file in Azure DevOps.
2. Go to **Pipelines** section, select **Library**.
3. Switch to **Secure files** tab.
4. Click **+ Secure file** button.

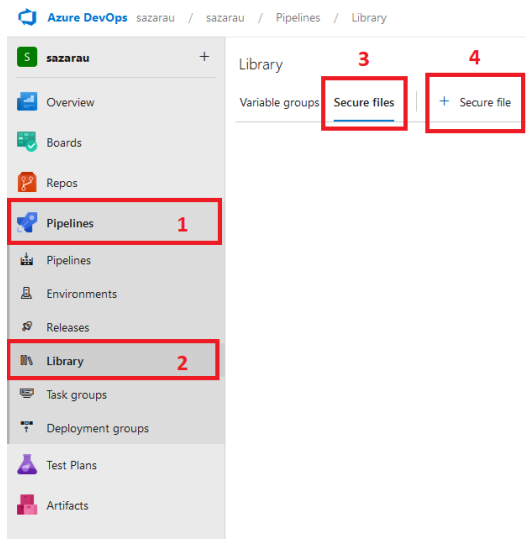

5. Click **Browse...** button and select the secure file.

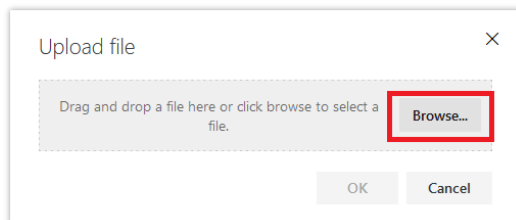

- Click **Ok**.

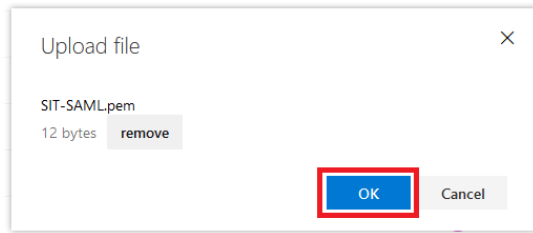

The file will be available in the list of secure files. Click **+ Secure file** again to add one more file, if needed.

9.2.2 Configure File Permissions for Pipeline

The following steps outline the process of configuring file permissions for pipeline:

- Click on the file name to open file properties.

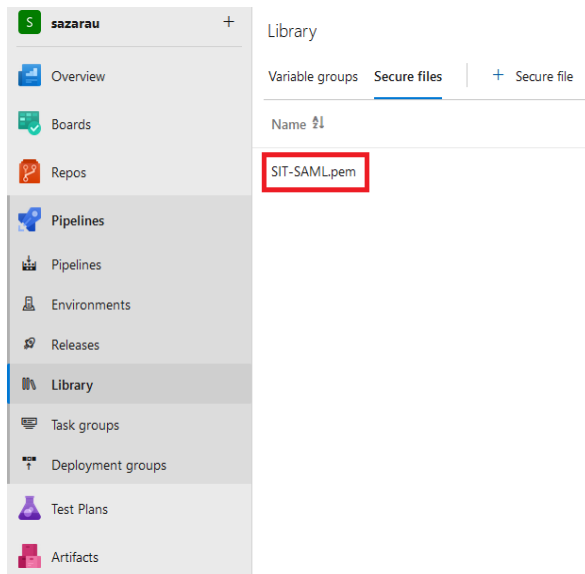

- Go to **Pipeline permissions** and from menu select **Open access**.

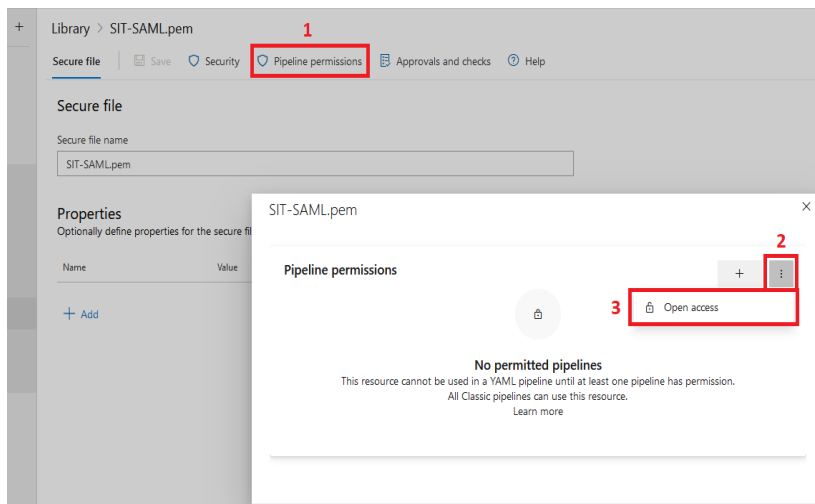

3. Click **Open access** to allow pipelines to download the file.

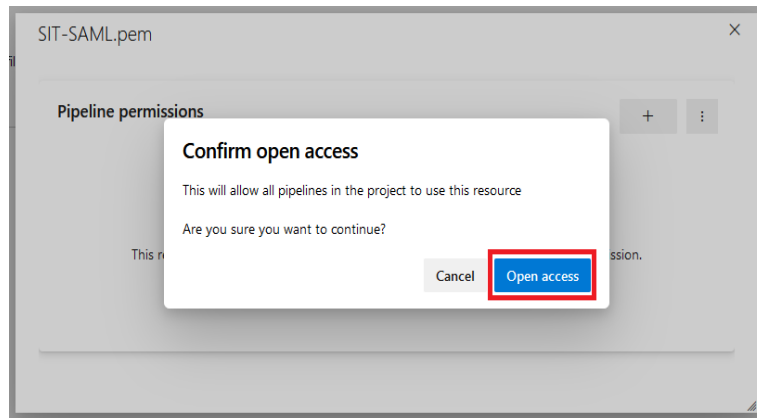

Once the permission has configured successfully, close the window.

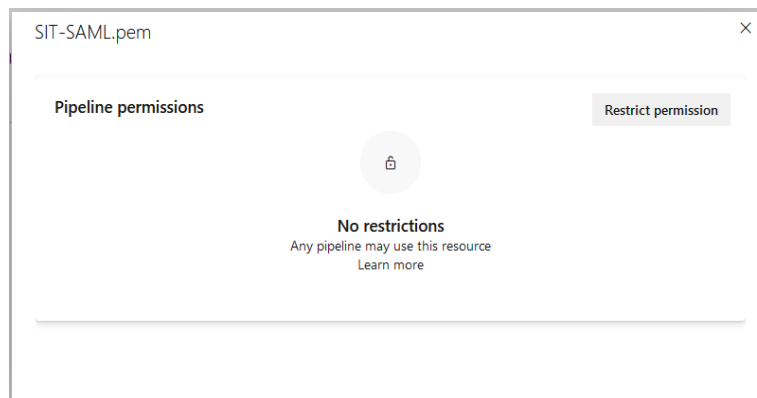

4. Now, add the certificate file name to a configuration file. It allows to use the file in pipelines. Click **Repos** and open TransformationsOfConfigFiles/environment-specific-secrets.yaml file.
5. Click **Edit**.

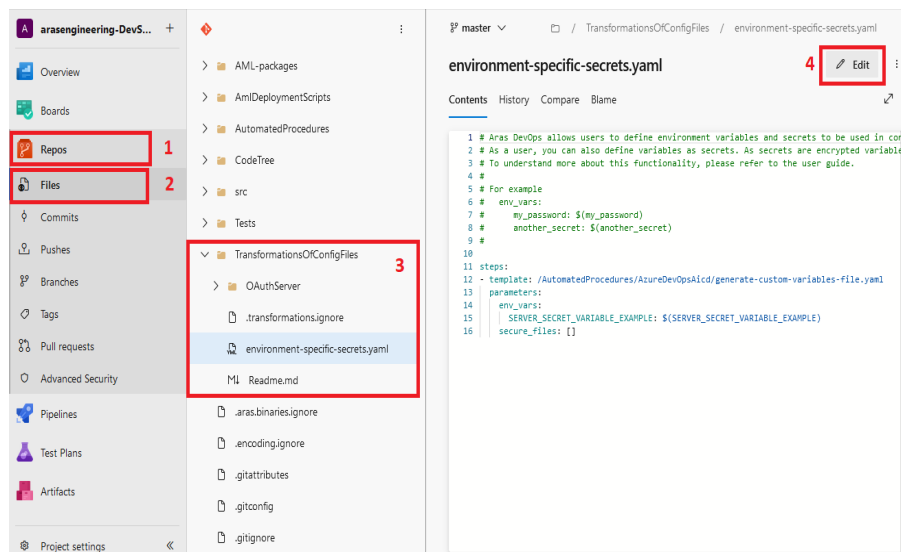

6. Add **secure_files** section, if missing. Add the file name to **secure_files** section. Note that all indents should be the same as in the screenshots below to have a valid yaml file.

```

1 # Aras DevOps allows users to define environment variables and secrets to be used in
2 # As a user, you can also define variables as secrets. As secrets are encrypted vari
3 # To understand more about this functionality, please refer to the user guide.
4 #
5 # For example
6 #   env_vars:
7 #     my_password: $(my_password)
8 #     another_secret: $(another_secret)
9 #
10
11 steps:
12 - template: /AutomatedProcedures/AzureDevOpsAicd/generate-custom-variables-file.yaml
13   parameters:
14     env_vars:
15       SERVER_SECRET_VARIABLE_EXAMPLE: $(SERVER_SECRET_VARIABLE_EXAMPLE)
16     secure_files:
17       - SIT-SAML.pem
18       - SIT-SAML-123.pem
19       - UAT-SAML.pem
20

```

7. Click **Commit**.

The screenshot shows a code editor interface for a file named `environment-specific-secrets.yaml`. The file content is displayed in a monospace font. A red box highlights the `secure_files` section of the code, which contains three entries: `- SIT-SAML.pem`, `- SIT-SAML-123.pem`, and `- UAT-SAML.pem`. A red box with the number '1' is placed next to this section. Another red box highlights the `Commit` button in the top right corner of the editor, with a red box containing the number '2' next to it. The interface also shows a 'Revert' button and a 'Highlight changes' option.

- Set comment to the commit (use the default commit message) and click **Commit**.

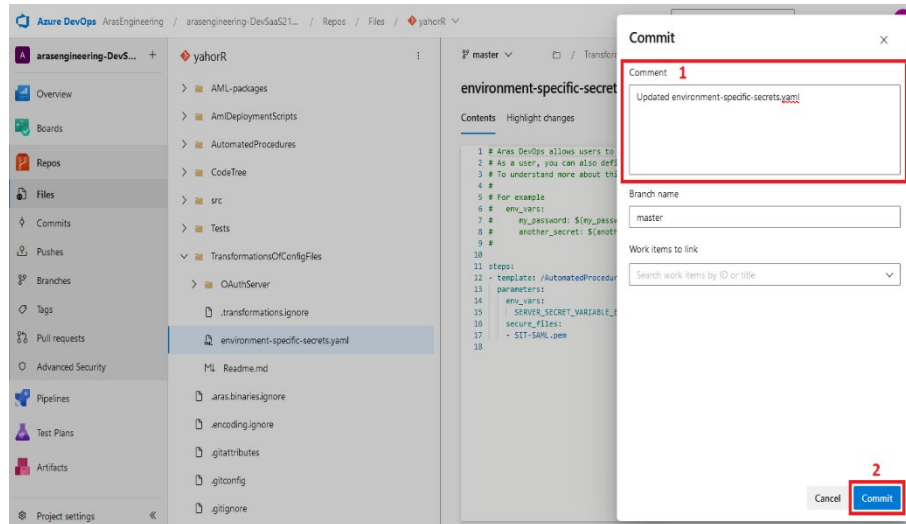

9.2.3 Add a Transformation with Link to Certificate

The following steps outline the process of adding a transformation with link to certificate:

- Add the transformation file for the following file to the repository:
TransformationsOfConfigFiles/OAuthServer/OAuthServer.Plugins.json

See and follow steps from section “Example of setup of Aras Innovator SAML 2.0 Authentication with Azure as Identity provider” for more information about setup SSO in general.

- Set the content to the transformation file with links to secure files. See example below:

```
{
  "@jdt.merge": {
    "@jdt.path": "$['OAuthServer.Plugins']",
    "@jdt.value": [
      {
        "Name": "Aras.OAuth.Server.Plugins.Saml2Authentication",
        "Enabled": true,
        "Options": [
          {
            "AuthenticationType": "Saml2-AzureAD2",
            "DisplayName": "Saml2 Google with signing",
            "ServiceProviderOptions": {
              "EntityId": "https://{OAuthServerURL}/Saml2-AzureAD/"
            },
            "IdentityProviderOptions": {
              "EntityId":
                "https://accounts.google.com/o/saml2?idpid=C014h6zu2",
            }
          }
        ]
      }
    ]
  }
}
```

```

        "MetadataSource": "MetadataOptions",
        "Metadata": {
            "SingleSignOnService": {
                "Location":
"https://accounts.google.com/o/saml2/idp?idpid=C014h6zu2",
                "Binding": "HttpRedirect"
            },
            "WantAuthnRequestsSigned": false,
            "SigningCertificate": {
                "SourceType": "File",
                "FilePath": "/app/stg-Google_2029-5-7-
91113_SAML2_0.pem"
            }
        }
    },
    {
        "Name": "Aras.OAuth.Server.Plugins.GenericUserMapper",
        "Enabled": true,
        "Options": [
            {
                "AuthenticationType": "Saml2",
                "InnovatorUserNameFormat": "{uid}",
                "ClaimActions": [
                    {
                        // Validate uid (default Innovator users are
denied).
                        "ActionName": "Validate",
                        "ActionOptions": {
                            "ClaimType": "uid",
                            "AllowPattern": ".+",
                            "DenyPattern":
"^admin$|^root$|^vadmin$|^authadmin$|^esadmin$",
                            "PatternOptions": [ "IgnoreCase", "Singleline" ]
                        }
                    }
                ]
            }
        ]
    }
}

```

```

        ]
    }
]
}
]
}
}
}

```

Note that the secure files will be in “**App**” folder. Use “**App**” folder when configuring **FilePath**.

See ‘Example of setup of Aras Innovator SAML 2.0 Authentication with Azure as Identity provider’ section to know more about full flow.

See ‘SAML2 Authentication Plugin Configuration’ section to know more about how to configure SAML plugin.

See ‘Generic user mapper’ section to know more about how to map users.

9.3 SAML2 Authentication Plugin Configuration

The Aras Innovator login may be customized using the SAML 2.0 Authentication Plugin described in this section. This plugin provides a way to use external identity providers by the SAML 2.0 protocol for Aras Innovator. The customization requires changes in the OAuth server configuration to enable the SAML 2.0 authentication plugin.

Use transformation mechanism to make changes in the configuration. See ‘Example of setup of Aras Innovator SAML 2.0 Authentication with Azure as Identity provider’ section to know more about full flow.

9.3.1 Base Configuration

To set up the base SAML 2.0 plugin configuration it is necessary to configure metadata for the identity and service providers. The metadata contains all the necessary information for communication between the providers.

The following is an example of the base SAML 2.0 plugin configuration:

```

{
  "Name": "Aras.OAuth.Server.Plugins.Saml2Authentication",
  "Enabled": true,
  "Options": [{
    "AuthenticationType": "<AuthenticationType>",
    "DisplayName": "<DisplayName>",
    "ServiceProviderOptions": {
      "EntityId": "<ServiceProviderEntityId>"
    },
    "IdentityProviderOptions": {
      "EntityId": "https://idp.example.com"
    }
  ]
}

```

Warning Make sure that the JSON is valid: the ',' symbol should appear between configuration sections. Also, make sure that Options is a JSON array with at least one object in it.

This configuration example allows to specify the following parameters:

- **AuthenticationType** – describes the name of the authentication scheme added to the OAuth server.
- **DisplayName** – the label that appears in the Login with dropdown on the Aras Innovator login page.
- **ServiceProviderOptions** – the options for configuring the service provider.
- **EntityId** – the unique identifier of the service provider (required).
- **IdentityProviderOptions** – the options for configuring the identity provider.
- **EntityId** – the unique identifier of the identity provider (required). If EntityId is a URL, it can be used by the service provider to load identity provider metadata. If the metadata is not located by the URL, refer to section Configuring Identity Provider Metadata to configure the identity provider metadata.

To make this base configuration work, after configuring the identity provider metadata (see the description of the EntityId property), it is necessary to configure service provider metadata in an identity provider management system. See section Configuring Service Provider Metadata for instructions.

Warning You must restart IIS after installing the SAML 2.0 authentication plugin.

9.3.2 Configuring Identity Provider Metadata

In order to use SAML 2.0 authentication, the service provider should know all the relevant information for communication with the identity provider.

In cases when the identity provider does not provide its metadata by URL to the EntityId property, it is possible to either specify the location for the metadata or to configure the metadata manually.

9.3.2.1 Configuring of metadata location

Metadata can be retrieved from the identity provider using either a URL or an xml file.

The following example shows the configuration of the SAML 2.0 plugin:

```
{
  "Name": "Aras.OAuth.Server.Plugins.Saml2Authentication",
  "Enabled": true,
  "Options": [{
    "AuthenticationType": "<AuthenticationType>",
    "DisplayName": "<DisplayName>",
    "ServiceProviderOptions": {
      "EntityId": "<ServiceProviderEntityId>"
    },
    "IdentityProviderOptions": {
      "EntityId": "https://idp.example.com",
    }
  }
  "MetadataSource": "MetadataLocation",
  "MetadataLocation": "https://idp.com/metadata"
}]
```

```
}
```

This configuration example specifies the following parameters:

- **IdentityProviderOptions** – the options for configuring the identity provider.
- **EntityId** – the unique identifier of the identity provider (required). It must be the same as the identifier in the metadata.
- **MetadataSource** – the type of source from which metadata will be loaded.
- **MetadataLocation** – the location from which metadata will be loaded (required when MetadataSource has MetadataLocation value). It can be a URL, an absolute path to a local file, or an app relative path.

9.3.2.2 Configuring metadata manually

The SAML 2.0 authentication plugin enables to specify metadata options for the identity provider if necessary.

The following is an example of a SAML 2.0 plugin configuration with identity provider metadata options:

```
{
  "Name": "Aras.OAuth.Server.Plugins.Saml2Authentication",
  "Enabled": true,
  "Options": [{
    "AuthenticationType": "<AuthenticationType>",
    "DisplayName": "<DisplayName>",
    "ServiceProviderOptions": {
      "EntityId": "<ServiceProviderEntityId>"
    },
    "IdentityProviderOptions": {
      "EntityId": "https://idp.example.com",

```

MetadataSource: "MetadataOptions",

```
      "Metadata": {
SingleSignOnService: {
      "Location": "https://idp.example.com/sso",
      "Binding": "HttpRedirect"
    },
ArtifactResolutionServices: [
      {
        "Index": "0",
        "Location": "https://idp.example.com/ars"
      }
    ],
WantAuthnRequestsSigned: false,
SigningCertificate: {
      "SourceType": "File",
      "FilePath": "..\\App_Data\\SigningCertificate.cer"
    }
  }
}
```

```

    }
  ]]
}

```

This configuration example specifies the following parameters:

- **IdentityProviderOptions** – the options for configuring the identity provider (optional like all child properties).
- **MetadataSource** – the source type from which metadata is loaded.
- **Metadata** – the configuration of the identity provider metadata (required if the MetadataSource has a MetadataOptions value).
 - SingleSignOnService** – describes the authentication request protocol endpoint to which the authentication request message (or artifact representing it) is delivered by the user agent (required if Metadata is configured).
 - Location** – the URL where the identity provider listens for incoming sign on requests (required if SingleSignOnService is configured). The URL has to be written in a way that the client understands, since it is the client web browser that will be redirected to the URL. Specifically, this means that using a host name only URL or a host name that only resolves on the network of the server will not work.
 - Binding** – the SAML binding supported by the endpoint (defaults to HttpRedirect). Other possible values are: HttpPost, Artifact.

Warning Single sign out (SingleLogoutService in terms of SAML 2.0 specification) is temporarily not supported.

- **ArtifactResolutionServices** – zero or more elements that describe indexed endpoints that are used for dereferencing a SAML artifact into a corresponding protocol message.
 - Index** – the non-negative integer that is used to distinguish the possible endpoints.
 - Location** – the URL to which a requester, having received an artifact, sends a request for artifact resolution (required if ArtifactResolutionServices is configured).
- **WantAuthnRequestsSigned** – a value (true or false) that indicates whether the identity provider wants the authentication request messages to be signed (defaults to false to support authentication flow without certificates).

Note: The WantAuthnRequestsSigned value is used together with the ServiceProviderOptions.SigningBehavior option and is only considered if SigningBehavior has IfldpWantAuthnRequestsSigned or Always values.

- **SigningCertificate** – the certificate that the identity provider uses to sign its messages. See the description of the identity provider certificate configuration in section Configuring identity provider signing certificates.

9.3.3 Configuring Service Provider Metadata

To use SAML 2.0 authentication, the identity provider should know all the information for communication with the service provider.

9.3.3.1 Base configuration of service provider metadata

It is not necessary to have any complex service provider metadata configuration, only two options must be configured in an identity provider management system – the Assertion Consumer Service URL and the Service Provider Entity ID:

1. The Assertion Consumer Service URL is the URL where SAML assertions are sent after a user has been authenticated. The URL is composed of the OAuth server URL, authentication type and /Acs postfix, e.g. `https://server.com/instance/OAuthServer/Saml2-AzureAD/Acs`. In case, there are internal and external clients which connect to the OAuth server via different URLs, the Assertion Consumer Service URL should be configured in a used identity provider management system according to each OAuth server URL.
2. Service Provider Entity ID – the unique identifier that is most often used as an audience of SAML assertion.

Warning Pay attention to case-sensitivity while configuring the Assertion Consumer Service URL. Make sure that it is in the same registry as the path where the OAuth server authentication cookie is stored (it is the OAuth server path – e.g., `Innovator/OAuthServer` from the Assertion Consumer Service URL example above).

Some identity providers make it possible to configure SAML 2.0 authentication using service provider metadata. This metadata is accessible via the Metadata Endpoint URL. The URL is composed of the OAuth server URL and the authentication type for example `https://server.com/instance/OAuthServer/Saml2-AzureAD`. See the next section for information about configuring service provider metadata.

9.3.3.2 Configuring metadata options

The following is an example of configuring service provider metadata:

```
{
  "Name": "Aras.OAuth.Server.Plugins.Saml2Authentication",
  "Enabled": true,
  "Options": [{
    "AuthenticationType": "<AuthenticationType>",
    "DisplayName": "<DisplayName>",
    "ServiceProviderOptions": {
      "EntityId": "<ServiceProviderEntityId>",
    }
  ]
  "Metadata": {
    "CacheDuration": "01:00:00",
    "WantAssertionsSigned": true,
    "Organization": {
      "Names": [
        "Aras Corp"
      ],
      "DisplayNames": [
        "Aras"
      ],
      "Urls": [
        "https://www.aras.com"
      ],
      "Language": "en"
    }
  },
}
```

```

        "Contacts": [
            {
                "Type": "Support",
                "Company": "Aras Corp",
                "GivenName": "John",
                "Surname": "Smith",
                "PhoneNumbers": [
                    "978-806-9400"
                ],
                "Emails": [
                    "info@aras.com"
                ]
            }
        ]
    },
    "IdentityProviderOptions": {
        "EntityId": "http://idp.example.com"
    }
}]]
}

```

This configuration example specifies the following parameters:

- **ServiceProviderOptions** – the options for configuring the service provider.
- **Metadata** – the configuration of service provider metadata.

Note: All Metadata configuration properties are optional.

- **CacheDuration** – the time interval during which anyone should cache the metadata presented by the service provider before trying to fetch a new copy (defaults to 1 hour).
- **WantAssertionsSigned** – the value (true or false) indicating whether the service provider wants assertions provided by the identity provider signed (defaults to true).
- **Organization** – the configuration of basic information about an organization responsible for a SAML entity.
 - Names** – one or more language-qualified names that may or may not be suitable for human consumption (required if Organization is configured, must have at least one item).
 - DisplayNames** – one or more language-qualified names that are suitable for human consumption (required if Organization is configured, must have at least one item).
 - URLs** – one or more language-qualified URLs that specify a location to direct a user for additional information. Note that the language qualifier refers to the content of the material at the specified location (required if Organization is configured, must have at least one item).
 - Language** – the language tag in the xml:lang XML attribute for all Names, DisplayNames and URLs (the default language is English – en language tag).

Note: Examples of language tags: ja (Japanese), de (German), fr (French).

See Tags for Identifying Languages specification for more info:
<https://tools.ietf.org/html/rfc5646>

- **Contacts** – the configuration of basic contact information for a person responsible for a SAML entity.
Type – the type of contact (defaults to Unspecified). Other possible values are: Technical, Support, Administrative, Billing, Other.
Company – the name of the company for the contact person.
GivenName – the first name of the contact person.
Surname – the surname of the contact person.
PhoneNumbers – zero or more string elements specifying a telephone number for the contact person.
Emails – zero or more string elements specifying an e-mail address of the contact person.

Note: All properties of Contacts configuration are optional.

9.3.3.3 Loading metadata to the identity provider

The metadata endpoint of the service provider is not accessible to the identity provider because it is located on the localhost. In this case service provider metadata (configured in section Configuring metadata options) can be downloaded from the Metadata Endpoint URL, saved as an XML file and imported to the identity provider side.

If the Metadata Endpoint URL of the service provider is accessible from the identity provider side, the URL can be configured in an identity provider management system.

After the service provider metadata is loaded in the identity provider, the base plugin configuration is completed.

9.3.4 Configuring Certificates

Both the service and identity providers can use certificates for their communication to make it more secure.

9.3.4.1 Configuring identity provider signing certificates

The Identity provider can use a certificate to sign its messages. The certificate can either be loaded from a file or from the Certificate Store.

The following is an example of configuring signing certificate loading from a file:

```
"IdentityProviderOptions": {
...
  "MetadataSource": "MetadataOptions",
    "Metadata": {
      "SigningCertificate": {
        "SourceType": "File",
        "FilePath": ".\\App_Data\\SigningCertificate.cer"
      }
    }
}
```

This configuration example specifies the following parameters:

- **SourceType** – the source type for certificate loading. It can be either `File` or `CertificateStore`.
- **FilePath** – the path to load the certificate from. The path is relative to the execution path of the application.

The following is an example of configuring signing certificate loading from the Certificate Store:

```
"IdentityProviderOptions": {
```

```

...
"MetadataSource": "MetadataOptions",
  "Metadata": {
"SigningCertificate": {
  "SourceType": "CertificateStore",
  "StoreLocation": "LocalMachine",
  "StoreName": "My",
  "FindType": "FindBySubjectDistinguishedName",
  "FindValue": "CN=CertificateSubject",
  "ValidOnly": true
}
}
}

```

This configuration example specifies the following parameters:

- **SourceType** – the source type for certificate loading, can be either File or CertificateStore (required if SigningCertificate is configured).
- **StoreLocation** – the location of the store to search for the certificate (required if SourceType has CertificateStore value). There is no default value for the property. Possible values are those from the System.Security.Cryptography.X509Certificates.StoreLocation enumeration: CurrentUser, LocalMachine.
- **StoreName** – the name of the certificate store to search for the certificate (required if SourceType has CertificateStore value). There is no default value for the property. Possible values are those from the System.Security.Cryptography.X509Certificates.StoreName enumeration: AddressBook, AuthRoot, CertificateAuthority, Disallowed, My, Root, TrustedPeople, TrustedPublisher.

Note: It is recommended to keep the certificate of the identity provider in the "Other People" store which is specified by the AddressBook enumeration value.

- **FindType** – the type of value from the findValue property that will be used to find the certificate (required if SourceType has CertificateStore value). There is no default value for the property. The following values from the System.Security.Cryptography.X509Certificates.X509FindType enumeration are supported: FindByThumbprint, FindBySubjectName, FindBySubjectDistinguishedName, FindByIssuerName, FindByIssuerDistinguishedName, FindBySerialNumber, FindByTemplateName, FindByApplicationPolicy, FindByCertificatePolicy, FindByExtension, FindByKeyUsage, FindBySubjectKeyIdentifier.

Note: It is recommended to use the FindBySerialNumber enumeration value for security reasons.

- **FindValue** – the search term (string) to find the certificate (required if SourceType has CertificateStore value). There is no default value for the property.

- **ValidOnly** – value (true or false) indicating that the certificate that will be loaded must be valid (defaults to false).

Note: The certificate is validated on expiration, correct signature, trusted root certificate and other parameters from the base certificates chain policy. See base policy errors: https://docs.microsoft.com/en-us/windows/win32/api/wincrypt/ns-wincrypt-cert_chain_policy_status#members.

9.3.5 Additional Authentication Options Configuration

The SAML 2.0 authentication plugin makes it possible to configure the authentication process by specifying additional options (not related to metadata and certificates).

The following is an example of a SAML 2.0 plugin configuration:

```
{
  "Name": "Aras.OAuth.Server.Plugins.Saml2Authentication",
  "Enabled": true,
  "Options": [{
    "AuthenticationType": "<AuthenticationType>",
    "DisplayName": "<DisplayName>",
    "ServiceProviderOptions": {
      "EntityId": "<ServiceProviderEntityId>"
    }
  ],
  "OutboundSigningAlgorithm": "Sha256",
  "SigningBehavior": "IfIdpWantAuthnRequestsSigned",
  "NameIdPolicy": {
    "AllowCreate": true,
    "Format": "Persistent"
  },
  "RequestedAuthnContext": {
    "ClassRef":
      "urn:oasis:names:tc:SAML:2.0:ac:classes:Password",
    "Comparison": "Minimum"
  },
  "IdentityProviderOptions": {
    "EntityId": "https://idp.example.com",
  }
}]
}
```

This configuration example specifies the following parameters:

- **OutboundSigningAlgorithm** – the signing algorithm for metadata and outbound messages (defaults to Sha256). The algorithm is used for both service and identity providers. Other possible values are: Sha514, Sha384 and Sha1 (case-insensitive, full algorithms signatures are also supported).
- **SigningBehavior** – the signing behavior of generated authentication requests (defaults to **IfIdpWantAuthnRequestsSigned** – sign authentication requests if the identity provider is configured for it using its WantAuthnRequestsSigned property). Other possible values are: Always (always sign all authentication requests) and Never (never sign any authentication requests).

- NameldPolicy** – controls the generation of the NameIDPolicy element in authentication requests to manage the name identifier returned in the subjects of assertions. The name identifier can be used for mapping an external user to an Aras Innovator user.
 - AllowCreate** – a nullable value (true or false) used to indicate whether the identity provider is allowed, in the course of fulfilling the request, to create a new identifier to represent the principal (defaults to null – it means that the attribute is not included in generated authentication requests). When false, the requester constrains the identity provider to only issue an assertion to it if an acceptable identifier for the principal has already been established.
 - Format** – the requested format of NameIDPolicy for generated authentication requests (defaults to Transient). Other possible values are: NotConfigured, Unspecified, EmailAddress, X509SubjectName, WindowsDomainQualifiedName, KerberosPrincipalName, EntityIdentifier, Persistent.

Warning The setting of this parameter does not guarantee the returning of NameID in a specified format. Some identity providers may ignore Format of NameldPolicy.

Note: If Transient format is specified, it is not permitted to specify AllowCreate according to the SAML 2.0 specification.

- RequestedAuthnContext** – specifies the authentication context requirements of authentication statements returned in response to a request or query.
 - ClassRef** – the URL reference identifying authentication context classes or declarations. It can be either a full URL, or a single word if using one of the predefined classes in the SAML 2.0 Authentication context specification.

Note: See section 3.4 of the SAML 2.0 Authentication context specification for predefined classes: <http://docs.oasis-open.org/security/saml/v2.0/saml-authn-context-2.0-os.pdf>.

- Comparison** – the comparison method that is used to evaluate the requested context classes or statements (defaults to Exact). Other possible values are: Minimum, Maximum, Better.

9.3.6 Aras Innovator User Setup

In order to use an authentication plugin with a mapper plugin, a user Item with the required login_name must exist in the Aras Innovator database with logon_enabled = true. The user's login_name must match the username received from the identity provider implemented in SAML 2.0.

9.3.6.1 Log in as an Authenticated User

To log in as a SAML 2.0 authenticated user, user must select the name of the configured SAML 2.0 identity provider from the Login with drop down. The Login screen appears as follows:

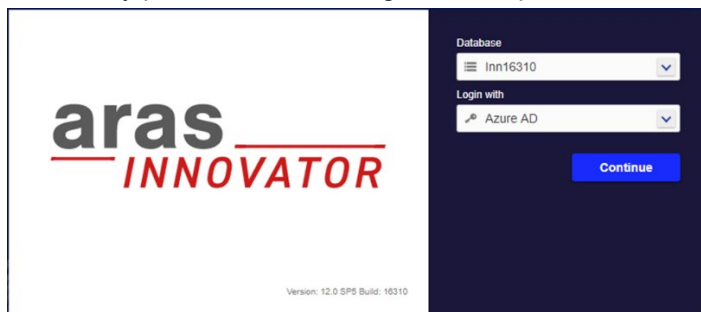

Press **Continue** to be redirected to the identity provider's login page.

9.3.6.2 Log in as a Standard User

To log in as a standard user, user must select local authentication from the Login with drop-down (display name by default is “Aras Innovator”). The Login screen appears as follows:

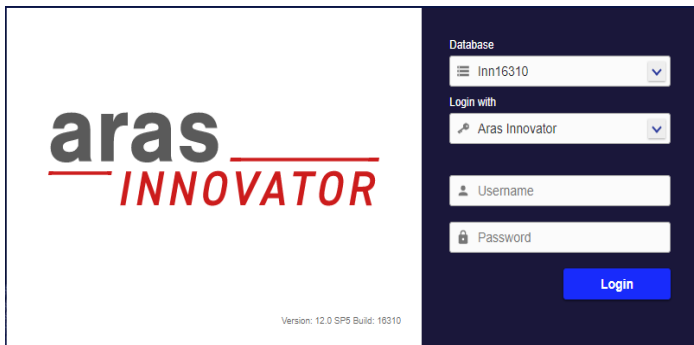

9.3.6.3 Switching Between Logon Types

For the end user convenience, the Aras Innovator login screen caches the logon method (SAML 2.0 or Standard) using cookies. To return to the logon mode selection dialog, it is necessary to add the prompt query parameter with select_account value to the application URL.

Another option is to clear `Aras.OAuth.Preferences.AuthenticationType` and `Aras.OAuth.Preferences.Database` cookies.

9.4 Generic User Mapper

Aras Innovator has the flexibility to provide many options to administrators when controlling the maintenance of user logins by providing multiple external authentication options. For each external authentication it is necessary to have a user mapper that should map an external user to an Aras Innovator user. Each external authentication has its own user format, so it is important that the user mapper can handle any user format. The Generic User Mapper can flexibly configure mapping an external user to an Aras Innovator user for multiple authentication types.

The Generic User Mapper customizes the user mapping process during external login. This plugin provides a flexible configuration of the user mapping process that allows the use of this plugin with any authentication type.

Use a transformation mechanism to make changes in the configuration. See 'Example of setup of Aras Innovator SAML 2.0 Authentication with Azure as Identity provider' section to know more.

9.4.1 GenericUserMapper Plugin Configuration

The GenericUserMapper plugin can be configured for multiple authentication types. Each authentication type mapping should be configured in separate options object.

Here is an example of the GenericUserMapper plugin configuration for multiple authentication types:

```
{  
  
  "Name": "Aras.OAuth.Server.Plugins.GenericUserMapper",  
  
  "Enabled": true,  
  
  "Options": [  
  
    {  
  
      "AuthenticationType": "<AuthenticationType1>",  
  
      "InnovatorUserNameFormat": "{<Claim1>}"  
  
    },  
  
    {  
  
      "AuthenticationType": "<AuthenticationType2>",  
  
      "InnovatorUserNameFormat": "{<Claim2>}"  
  
    }  
  
  ]  
  
}
```

Warning Ensure the `Options` is a JSON array with at least one object in it.

The plugin allows users to specify the following parameters for the options object:

- **AuthenticationType** – the name of the authentication scheme registered in the OAuth server for which these mapping options should be applied (this value should correspond to the AuthenticationType value of the authentication plugin).
- **InnovatorUserNameFormat** – a username format string that consists of fixed text intermixed with named placeholders. A placeholder is a claim type that appears enclosed in braces. The result is a string where each placeholder is replaced by the corresponding claim value. Here is an example of a username format string:
"Prefix_{<Claim1>}_{<Claim2>}_Postfix".

Warning The maximum length of Aras Innovator username is 32 characters, so be aware of this when configuring InnovatorUserNameFormat.

- **ClaimActions** – actions that should be performed to claims before generating a username based on InnovatorUserNameFormat.

9.4.1.1 Claim actions configuration

Claim action configuration objects contain the following settings:

- **ActionName** – name of action.
- **ActionOptions** – action configuration.

The GenericUserMapper plugin supports the following types of actions:

- **CreateFrom** – creates new claim from value.
- **Validate** – allows or denies claim values.

CreateFrom Action

The `CreateFrom` action allows users to get a value from one claim, edit it using a regular expression and save it in a new claim.

The `CreateFrom` action configuration contains the following options:

- **ClaimType** – type of new claim where a new value is set.
- **SourceClaimType** – type of claim where a value should be used.
- **ReplacePattern** – the regular expression pattern to match.
- **Replacement** – the string to replace the match.
- **PatternOptions** – options for matching.

Note: See supported `PatternOptions` values: <https://docs.microsoft.com/en-us/dotnet/api/system.text.regularexpressions.regexoptions#fields>.

The `CreateFrom` action uses the following algorithm:

1. Get value from `SourceClaimType` claim.
2. Apply the regular expression from `ReplacePattern` with the options of matching from `PatternOptions`.
3. Replace the matched value with `Replacement`.
4. Save the new value in a new `ClaimType` claim.

The following is an example of configuring a CreateFrom action which takes the value from the claim
`"http://schemas.xmlsoap.org/ws/2005/05/identity/claims/emailaddress"`,
 replaces all text after at inclusive with an empty string and saves the new value in claim
 username:

```
{
  "ActionName": "CreateFrom",
  "ActionOptions": {
    "ClaimType": "username",
    "SourceClaimType":
"http://schemas.xmlsoap.org/ws/2005/05/identity/claims/emailaddress",
    "ReplacePattern": "@.+",
    "Replacement": "",
    "PatternOptions": [ "IgnoreCase", "Singleline" ]
  }
}
```

Note: Only the full format of claim types is supported.
 To validate regular expressions with different values, it is recommended to use regex
 tools which are available online.

Validate Action

The Validate action enables users to verify a claim value by checking it against specified allow
 and deny regular expression patterns.

The Validate action configuration contains the following options:

- **ClaimType** – the type of claim value that should be used.
- **AllowPattern** – the regular expression pattern to match allowed values. This option might not
 be presented if DenyPattern is set.
- **DenyPattern** – the regular expression pattern to match denied values. This option might not
 be presented if AllowPattern is set.
- **PatternOptions** – the list of regular expression options that are used to find a match.

Note: See supported PatternOptions values: <https://docs.microsoft.com/en-us/dotnet/api/system.text.regularexpressions.regexoptions#fields>.

The Validate action uses the following algorithm:

1. Get the value from the ClaimType claim.
2. Apply a regular expression from AllowPattern with the option of matching from
 PatternOptions. If there is no match an error is returned.
3. Apply a regular expression from DenyPattern with the options of matching from
 PatternOptions. If there is a match, an error is returned.

The following is an example of configuring a Validate action that allows all values and denies a value if it is equal to any of the standard Aras Innovator administrators:

```
{
  "ActionName": "Validate",
  "ActionOptions": {
    "ClaimType":
"http://schemas.xmlsoap.org/ws/2005/05/identity/claims/name",
    "AllowPattern": ".*",
    "DenyPattern":
"^admin$|^root$|^vadmin$|^authadmin$|^esadmin$",
    "PatternOptions": [ "IgnoreCase", "Singleline" ]
  }
}
```

Note: Only the full format for claim types is supported.

9.4.1.2 Generic User Mapper Execution

Claim actions are executed in the same order as they are defined in a configuration. After all actions are executed, the Generic User Mapper creates a username using the `InnovatorUserNameFormat` option.

See example below:

```
{
  "Name": "Aras.OAuth.Server.Plugins.GenericUserMapper",
  "Enabled": true,
  "Options": [
    {
      "AuthenticationType": "Saml2-AzureAD",
      "InnovatorUserNameFormat": "{username}",
      "ClaimActions": [
        {
          "ActionName": "CreateFrom",
          "ActionOptions": {
            "ClaimType": "username",
            "SourceClaimType":
"http://schemas.xmlsoap.org/ws/2005/05/identity/claims/nameidentifier",
            "ReplacePattern": "@.+",
            "Replacement": "",
            "PatternOptions": [ "IgnoreCase", "Singleline"
]
          }
        },
        {
          "ActionName": "Validate",
          "ActionOptions": {
            "ClaimType": "username",
            "AllowPattern": ".+",
            "DenyPattern":
"^admin$|^root$|^vadmin$|^authadmin$|^esadmin$",
            "PatternOptions": [ "IgnoreCase", "Singleline"
]
          }
        }
      ]
    }
  ]
}
```

The following is an example of `GenericUserMapper` plugin configuration for SAML2 authentication:

```
{
  "Name": "Aras.OAuth.Server.Plugins.GenericUserMapper",
  "Enabled": true,
  "Options": [
    {
      "AuthenticationType": "Saml2",
      "InnovatorUserNameFormat": "{uid}",
      "ClaimActions": [
        {
          // Validate uid (default Innovator users are denied).
          "ActionName": "Validate",
          "ActionOptions": {
            "ClaimType": "uid",
            "AllowPattern": ".+",
            "DenyPattern":
"^admin$|^root$|^vadmin$|^authadmin$|^esadmin$",
            "PatternOptions": [ "IgnoreCase", "Singleline" ]
          }
        }
      ]
    }
  ]
}
```

10 Packaging

Aras Innovator is a low-code platform, which means user can add very little code to achieve outstanding results rapidly.

It also means user can use configuration to express business rules, such as a life cycle map.

When working directly with an instance of Aras Innovator, these changes are stored anonymously within and can reference any other items already in the system and vice versa.

Making such changes directly in a business-critical system serving users is not good practice. As mentioned earlier, a central focus of DevOps is to instill the discipline of well-managed solution configurations, including change management and implementation.

The following sections explain how to export these changes into named packages, define explicit dependencies, and commit the changes for proper configuration and version control.

This way, it is ensured that the build system can replicate the swiftly accomplished interactive tasks - thus introducing configuration and version control discipline to the low-code product.

10.1 Summary of Modeling

The process of building a new application can be divided into two primary aspects:

- Data modeling (schema)
- Interaction (business rules, UX)

This is done on an existing system with standard products from Aras, Modules from 3rd Parties, or earlier work by the user's company for various reasons.

The new applications must consider all the existing work when modularizing, packaging, and building.

The two diagrams below illustrate that the new application can be simple or ambitious.



The diagram below summarizes the impact of anonymous items in an instance and the effect of defining, exporting, and providing packages to the build system.

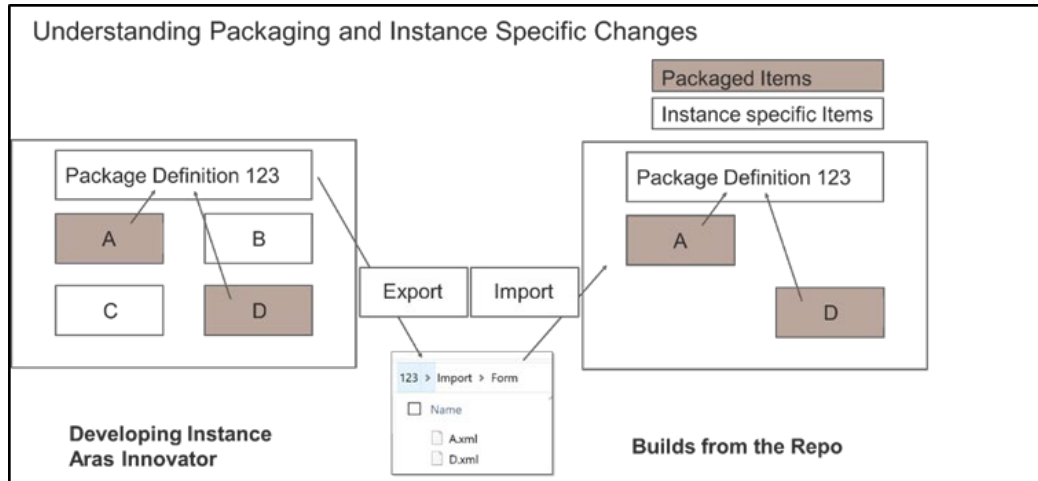

On the left, the user has four items (A, B, C, and D). A, and D represent new or modified items which are properly packaged, exported, copied, and assigned to the change control system Git. B and C represent Innovator instance specific items which are not intended for use in the next build and therefore consequently not packaged.

The build system then produces the instance on the right. It's important to observe that the Aras Innovator instance on the right excludes items B & C, showcasing the capability to dictate what DevOps builds. This capacity to specify what DevOps creates is a foundational element of utilizing DevOps.

10.2 Review of Packaging Scenarios

10.2.1 Case 1

Case 1 represents a straightforward addition of properties to standard classes for which user must provide forms. Notice the specifications for Delta Extraction tool. By default, it is false.

Packaging Scenarios – Case 1

When your project needs to add properties to **existing** standard production components.
e.g., Document and Part

Package Definition PLM

Part
[prp_property1]

Document
[prp_property1]

- Keep items in their original AML package, this means, too, avoid moving items from Standard Aras Packages into custom packages
- Avoid modifications of Core packages

Enable the Delta Extraction tool by setting

- Use.Delta.Extraction.Tool parameter to true
- in AutomatedProcedures\Default.Settings.include

```

<!--
  Use.Delta.Extraction.Tool - fFlag to enable usage of Delta Extraction tool
  for AML-Packages. See description in Documentation folder.
-->
<property name="Use.Delta.Extraction.Tool" overwrite="false" value="false" />

```

```

<package name="com.myproject.PLM" path="myproject/plm/Import">
  <dependson name="com.aras.innovator.solution.PLM" />
</package>

```

Adding properties and hence modifying core package could not be avoided or was more efficient

- Enable the delta extraction tool
- Make the change without moving items from the existing packages.

Builds from the Repo

10.2.2 Case 2

Case 2 represents a situation in which the user needs a relation between the new item types and the existing item types. User must now define relationships and specify dependencies.

Packaging Scenarios – Case 2

When your project needs to make references to existing standard production components by relating to the **existing** items. e.g., Document and Part

- Keep items in their original AML package, this means, too, avoid moving items from Standard Aras Packages into custom packages
- Avoid modifications of Core packages

Package Definition PLM

Part

Document

Package Definition MyPLM

PRJ_Part

property1

property2

Define your new items.
Define your new relationships to existing items property pointers. Define your forms. Do all this without altering the existing items.

Update your imports.mf file appropriately to indicate your dependencies.

```

<package name="com.myproject.PLM" path="myproject/plm/Import">
  <dependson name="com.aras.innovator.solution.PLM" />
</package>
                    
```

Builds from the Repo

10.2.3 Case 3

In case 3, if user has effectively introduced a circular dependency, it will not be recognized in the Aras Innovator instance utilized for development. Aras Innovator automatically resolves all the dependencies since all items are already present. When using a build system, if packaging and modularization are not explicitly specified, the loading sequence can be misaligned and fail. To avoid such failures, explicitly specify packages and their dependencies.

Packaging Scenarios – Case 3

When your project needs to make existing items reference new properties or items in your project. e.g., Document and Part

- Keep items in their original AML package, this means, too, avoid moving items from Standard Aras Packages into custom packages
- Avoid modifications of Core packages

Package Definition PLM

Part

Document

Package Definition MyPLM

PRJ_Part

property1

property2

Define your new base package (or common) items
Define your new relationships to existing items property pointers. Define your forms. Do all this without altering the existing items.

Update your imports.mf file appropriately to indicate your dependencies.

```

<package name="com.myproject.PLM.base" path="myproject/plm/base/Import" />
<package name="com.aras.innovator.solution.PLM" path="PLM/Import">
  <dependson name="com.myproject.PLM.base" />
</package>

<package name="com.myproject.PLM" path="myproject/plm/Import">
  <dependson name="com.aras.innovator.solution.PLM" />
</package>
                    
```

Package Definition MyPLMBase

PRJ_base

property1

property2

Builds from the Repo

10.3 Packaging Tools and Methods

The Aras Innovator architecture is designed for customization of standard Aras Solutions/Apps and for building custom Solutions.

Solution Packaging is the mechanism that allows Solution Developers to register customizations in Packages so they can be extracted and transported to other Aras Innovator installations. For example, from a development to a test environment.

The items are organized into packages. A package element (identified by its GUID) cannot be added to multiple packages. Align folder names with the packages they contain for ease of identification.

We recommend using packaging when creating items, lists, properties etc. in an Aras Innovator instance, since packaging is mandatory for use in CI/CD. Packages can be exported and imported.

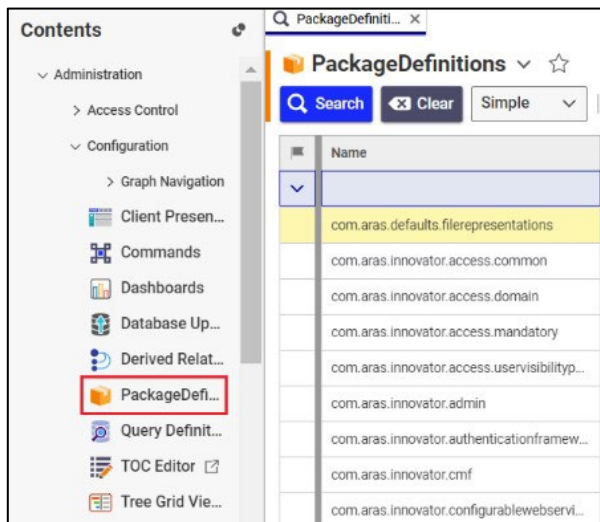

A newly installed Aras Innovator database contains Package Definitions of two types:

- **Core Packages** – These packages are used to define the basic structure of every Aras Innovator database, regardless of what solutions are used. Core packages are not meant to be overwritten or customized.
- **Solution Packages** – These packages define the elements that comprise the definition and functional rules of different custom data models created in the context of the project.

To learn about Standard Solution Packaging Tools, please see section Appendix II: Standard Solution Packaging Tools.

The following section provides an illustration related to the topic discussed above in the preceding section.

10.4 Create and Manage New Application

Customization in Aras Innovator can consist of modifying existing applications, but also in creating completely new applications needed to solve custom business needs. The goal of this section is to describe the main steps that will need to be taken.

A new application normally results in a new AML package with its own package definition. The package definition contains all changes made to instances of Aras Innovator.

The process of creating a new package requires several steps:

1. Create a new package.
2. Export package to the file system, locate the results properly in the repository directories and update the manifest file to include not only the existing packages, but also the newly added one. Modify the manifest file to include not only the existing packages, but also the newly added one.
3. Assign the new and modified files to the Git repository with commit or stage including the manifest file.
4. If a new package is created, it is recommended to use Java naming conventions for packages (lowercase and dots indicating a hierarchy) and align folder names with the packages they contain.

Note: Whenever a user has updated any sections of the repository the new or modified files need to be staged or committed to become part of the next build.

10.4.1 Creating a Package Definition

To set up a new application on Aras Innovator, the user must create a package by first creating a package definition with its dependencies and then export the package.

In this case the manifest file for the import must be adapted and needs commit or stage to version control system.

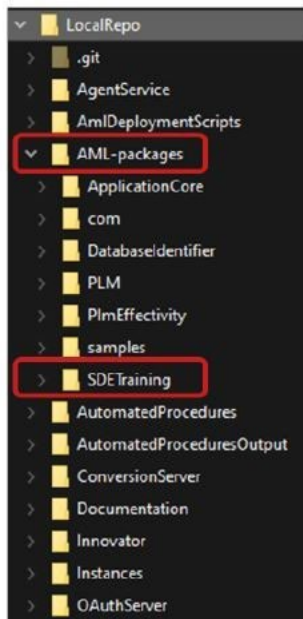

The following steps outline the process of creating a package definition:

1. Login into Aras Innovator instance.
2. From the **Table of Contents**, expand **Administration>Configuration** and select **PackageDefinitions**.

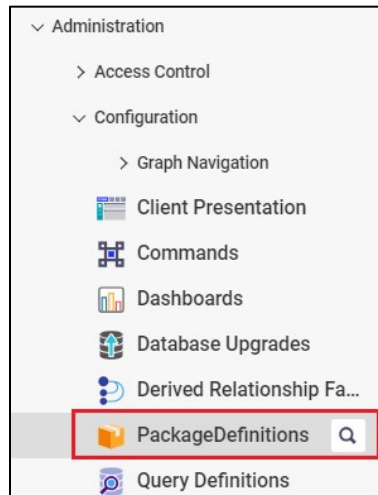

3. Click **Create New PackageDefinition**.

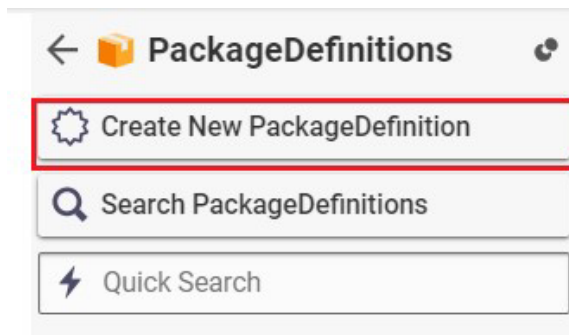

4. On the package definition form enter the name of the **PackageDefinition**. For example, `com.aras.training.sde`.

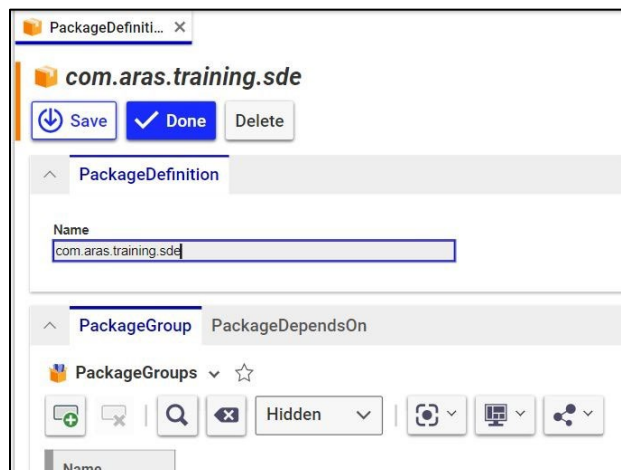

5. Create a test item and add it to the new package.

10.4.2 Export Package and Update the Imports Manifest File

The Manifest file describes the list of packages that will be imported during solution deployment and dependencies between those packages. When a custom package is created and will need to be imported during project deployment, it needs to be included into the manifest file.

The following steps outline the process of exporting and updating the Imports Manifest File:

1. Export the new Package.
2. Open the resulting manifest file. Copy the package name from the import.mf file. For example:

```
<package name="com.aras.training.sde" path="sde\Import" />
```

3. Open the manifest file from the local repository: C:\ {Working Directory} \AML-packages.
4. Paste the code copied in step 2 inside the import.mf file in the local repository.

For example:

```
<imports>
<package name="com.aras.training.sde" path="sde\Import">
<dependson name="com.aras.innovator.solution.ApplicationCore" />
</package>
</imports>
```

5. For cleanup, delete the test item which was the only item in the package com.aras.training.sde.

10.4.3 Confirming Manifest Changes in Version Control System

Verify the modifications made to the manifest file before committing them to the repository. This process ensures that the changes are accurate and in line with the contributor's intentions.

It typically involves checking the status of the Version Control System (VCS), reviewing the modifications made to the manifest file using the diff command specific to the VCS, and then committing the changes if they are satisfactory. The exact steps and commands may vary depending on the VCS which is used.

11 Update Repository to Use Single Package

The latest release of Aras DevOps offers all essential core packages into a single NuGet Package. This simplifies the process of creating repositories and ensures that the core packages work seamlessly together.

The following steps outline the process of updating the work repository to use the Single Packages:

1. On **Azure DevOps**, select **Repos**.

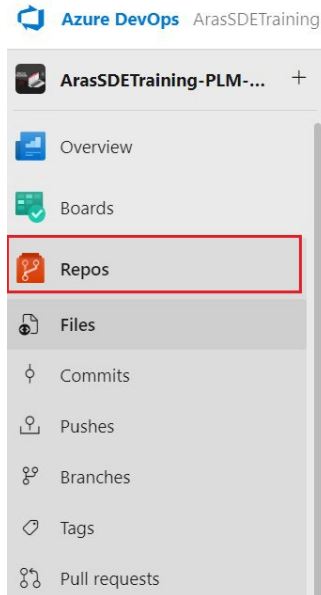

2. Click **Clone** to clone the repository that needs to be updated. The **Clone Repository** dialog box appears with the repository's clone URL.

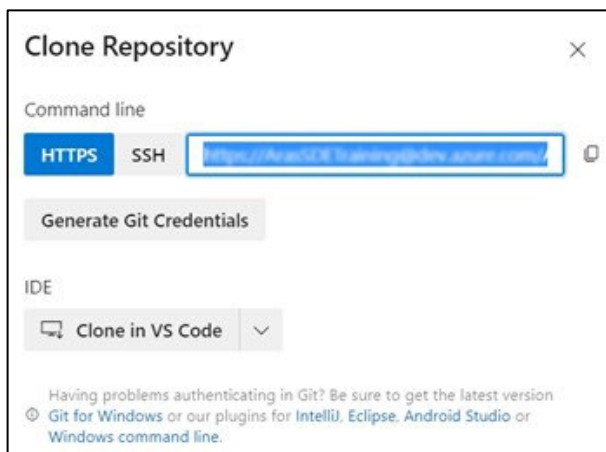

3. Copy the clone URL (HTTPS or SSH). An example URL: https://dev.azure.com/{organization}/{project}/_git/{repository}. Use any version control tools required to clone the repository.
4. In the version control tool's interface, find the option to clone or create a new repository.
5. Paste the clone URL copied from the Azure DevOps project. Browse to the destination directory to clone the repository.

Optional: Depending on the tool that is used, additional configuration options are available during the cloning process. This could include selecting branches, specifying authentication credentials, or choosing the desired clone depth.

6. Click **Clone** within the version control tool.
7. Open **Windows PowerShell** as Administrator.
8. Run **./repo-init.ps1** command for initializing the repository with initial packages.
9. To identify the source name of the package that points to the NuGet feed containing the Single Package, run **Get-PackageSource** command.

```
PS C:\Projects\NewRepo\Work\Work.ruchira.walavalkar\Work> Get-PackageSource
```

Name	ProviderName	IsTrusted	Location
nuget.org	NuGet	False	https://api.nuget.org/v3/index.json
azure.artifacts.aras.com	NuGet	True	https://pkgs.dev.azure.com/ArasSDET/...
PSGallery	PowerShellGet	False	https://www.powershellgallery.com/api/v2/
azure.artifacts.aras.com	PowerShellGet	True	https://pkgs.dev.azure.com/ArasSDET/...

A list of single package dependencies is required for correct update and will be compared to the individual packages specified in the AutomatedProcedures/tools/packages.config file.

10. To get dependencies of the NuGet package, run **Find-Package -Name "Aras.Saas.DevOpsFramework.Msi" -RequiredVersion "<single_package_version>" -Source <package_source_name> -IncludeDependencies | Select Name**

```
PS C:\> Find-Package -Name "Aras.Saas.DevOpsFramework.Msi" -RequiredVersion "1.2.0.13823" -Source azure.artifacts.aras.com -IncludeDependencies | Select Name
```

```
Name
----
Aras.Saas.DevOpsFramework.Msi
Aras.DeltaExtraction.CommandLine
Aras.Deployment.Tool
Aras.Update.Cmd
Aras.ConsoleUpgrade
Aras.LanguageTool
Aras.Crt.Core
NAnt
NAnt.Contrib.Portable
MSBuild.Microsoft.VisualStudio.Common
Microsoft.Experimental.IO
Microsoft.Extensions.FileSystem
Microsoft.Web.Xdt
Aras.Nant.Shim
Microsoft.PowerShell.5.ReferenceAssemblies
Aras.Crt.SeleniumTests
Aras.Crt.IntegrationTests
Aras.Crt.AzurePipeline
```

11. Navigate to the local repository and select AutomatedProcedures file.
12. Click **Tools** and open **packages.config** file.

13. Locate the dependencies identified in step 10 and remove them from the **packages.config** file. The following screenshot demonstrate the example of packages.config file with all single package dependencies:

```
<?xml version="1.0" encoding="utf-8"?>
<packages>
  <package id="Aras.IOM" version="14.0.15.38102" />
  <package id="Aras.Crt.InnovatorConfigs" version="14.0.15.38102" />
  <package id="Aras.DeltaExtraction.CommandLine" version="1.0.0.20" />
  <package id="Aras.Deployment.Tool" version="1.2.0.221" />
  <package id="Aras.Update.Cmd" version="1.22.1328" />
  <package id="Aras.ConsoleUpgrade" version="14.0.17.38577" />
  <package id="Aras.LanguageTool" version="14.0.17.38577" />
  <package id="Aras.Crt.Core" version="1.2.0.13732" />
  <package id="Aras.Nant.Shim" version="1.2.0.13732" />
</packages>
```

Single
Package
Dependencies

The following screenshot demonstrate the example of packages.config file after the dependencies are removed:

```
<?xml version="1.0" encoding="utf-8"?>
<packages>
  <package id="Aras.IOM" version="14.0.15.38102" />
  <package id="Aras.Crt.InnovatorConfigs" version="14.0.15.38102" />
  <package id="Aras.Saas.DevOpsFramework.Msi" version="1.2.0.13823" />
</packages>
```

14. To restore the new packages list with dependencies from NuGet, open Windows PowerShell as Administration and run the following command: `Restore-ArasDevopsPackages -WorkRepository "<path_to_work_repository>".`

Add the work repository path as a parameter. Ensure that the command is executed successfully, and no errors appear in the console.

Note: The `init.ps1`, `update.ps1` and `cleanup.ps1` scripts are executed (if present) only for packages with names starting with `Aras*`.

15. Verify any changes to NuGet packages by checking the output of `Restore-ArasDevopsPackages -WorkRepository "<path_to_work_repository>"` command on Window PowerShell console.

This display indicates which packages have been added, updated, or deleted in the work repository. Please see below screenshot:

```
NuGet packages added to the work repository as a result of 'Restore-ArasDevopsPackages' call:
Name                                     Version
----                                     -
Aras.Crt.AzurePipeline                   1.2.0.13823
Aras.Crt.IntegrationTests                 1.37.3838
Aras.Crt.SeleniumTests                   1.37.3838
Aras.Saas.DevOpsFramework.Msi            1.2.0.13823

NuGet packages updated in the work repository as a result of 'Restore-ArasDevopsPackages' call:
Name           NewVersion  OldVersion
----           -
Aras.Crt.Core  1.2.0.13823 1.2.0.13732
Aras.Nant.Shim 1.2.0.13823 1.2.0.13732
```

16. Commit the changes using the required version control system.

12 Change Management and Implementation

Aras enforces a strict Solution Configuration Management discipline. The solution includes:

- Standard Aras Innovator Platform – the release is created regularly by Aras engineering and tracked with versioning (Such as Aras Innovator Release 26, please see the support matrix.
- Standard Aras Innovator Applications - User can include them with the base Aras Innovator platform.
- Configuration and Customizations specified by the customer and implemented by the customer and or customer's agents such as Aras Solution Delivery Services and 3rd Party Systems Integrators. These includes:
 - Workflow configurations
 - Reports
 - Configurations such as adding new properties to items
 - Forms
 - Integrations to various other systems
 - Enhancements (customizations for specific purposes)

The project manages all of the above to ensure comprehensive Solution Configuration Management. Aras Cloud policy requires a project to provide the following approvals to get a specific solution configuration into production or modify the solution.

- Staging Environment: The Staging Environment allows users to complete final preparations and checks on a thoroughly tested deployment before it goes into production. It closely mirrors the production environment and serves as the last phase before deployment. Requests for provisioning and deprovisioning staging environments for production are initiated by the project team.
- System Qualification Approval: The system satisfies requirements as tested in the SIT environment.
- Functional Qualification Approval: The system configuration has been completed and is acceptable to the user community as tested in the UAT environment.
- Data Qualification Approval: The system contains the required initial data.
- Production Qualification Approval: Approval to go live and an invitation to the user community to use the system. Testing for this approval is conducted in the preproduction environment. The approach of solution configuration management pertains to the initial implementation as well as subsequent improvements, bug fixes, and any modifications that change the system's configuration.

12.1 Production Countdown Sequence

Aras understands the need for flexibility during development and will interfere with the project's chosen practices.

However, during the countdown sequence to production deployment, Aras requires a protocol to ensure a smooth transition and secure approvals needed.

Aras focuses on the following branches:

- Development
- SIT
- UAT
- Staging
- Production

As part of the production deployment sequence, Aras mandates that the project team integrate their release candidate from the development branch into the "sit" branch prior to deploying it in the SIT environment.

During deployment, the project team can deploy from any Work (team) repository branch to the SIT environment to support ongoing testing.

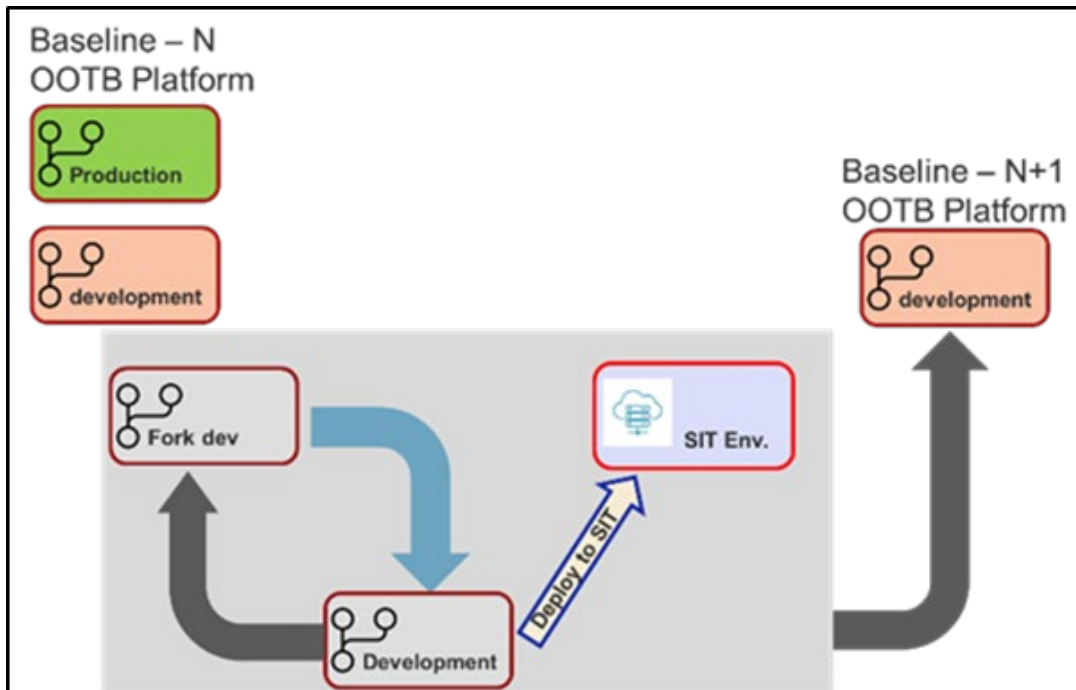

During the countdown sequence, the change implementation policy requires the project team to deploy to the SIT environment only from the "sit" branch. The practice of deploying to SIT only from the "sit" branch during the countdown sequence helps ensure alignment. The customer is required to identify the build for which they approve for System Qualification.

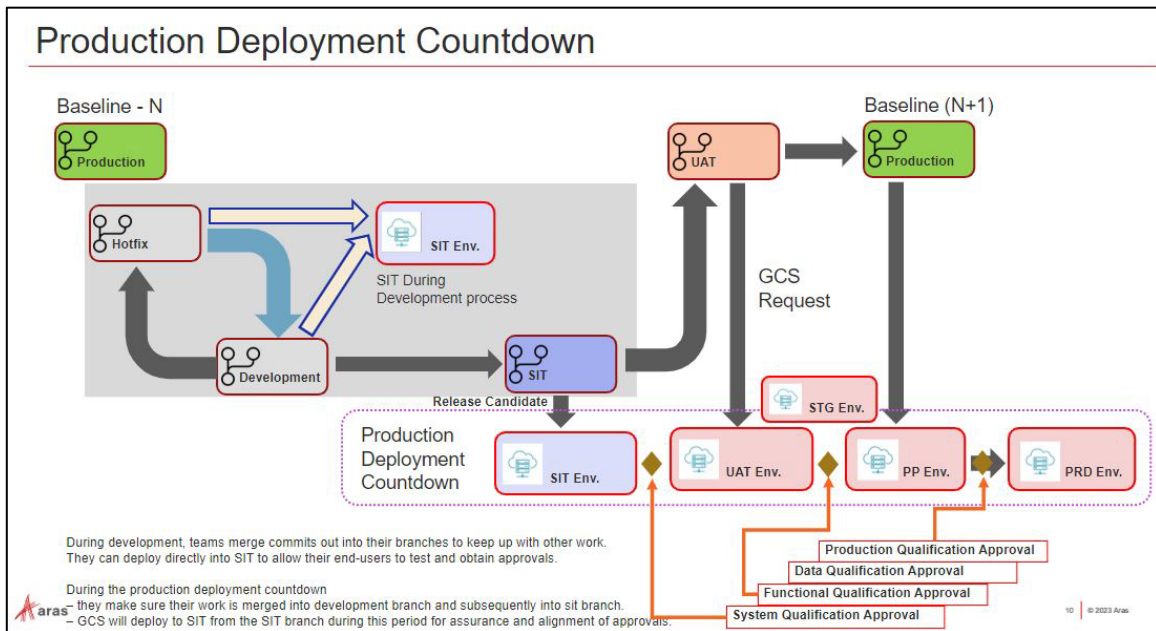

Aras mandates that the project team obtains a "System Qualification Approval - SQA" from the client to conclude SIT testing. This approval signifies that the client is content with the entire solution. As needed, all necessary integrations, SSO connections, CAD, and Office connectors have been established.

Note that the project team may have identified a release candidate, deployed it to SIT, collected feedback, and performed remediation to obtain System Qualification Approval. Aras does not dictate the number of cycles, just that the customer provides SQA before deployment to UAT.

Once the "SQA" is obtained, the project team immediately asks Aras to initiate the suitable build deployment in the UAT environment. The project team should prepare and deploy to the UAT environment from the "uat" branch. In collaboration with the client, the project team facilitates a system review by the end-users, leading towards the Function Qualification Approval. The client must provide FQA before PQA.

In projects that involve data migration, the project team is required to secure Data Qualification Approval - DQA. To obtain DQA, the project team must request production environment provisioning and necessary endpoints to run the data import. Once the project team has imported the data, the team must ask the customer to review the data and approve data quality.

The project team must request the UAT, staging, and production environments with the customers' approval. The staging environment is used both for importing data from other systems and serves as pre-production to perform final testing to secure Production Qualification Approval.

13 Branding Customization

Branding customizations enable contributors to use their own logos and banners for Aras Innovator.

13.1 Splash Screen

The following steps outline the process to change the Aras Innovator splash screen:

1. Select a background Image and obtain the customer's logo to be applied to the splash screen.

Note: Contributors needs a tool to manipulate SVG images. Use any required tool.

2. In the following directory add the Background image and Customer logo obtained from step 1:
C:\ {working directory}\Instances\dev\OAuthServer\wwwroot\images

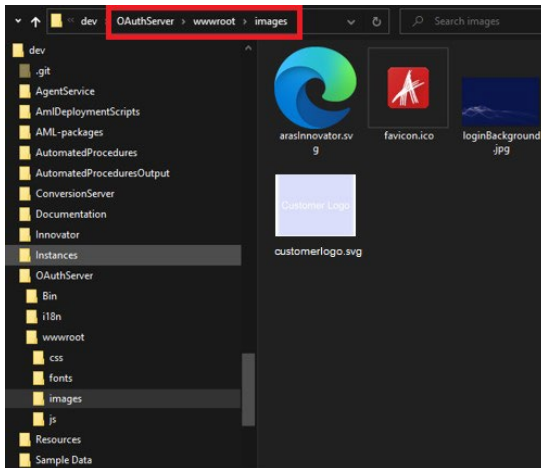

3. From C:\{working directory}\TransformationsOfConfigFiles\ directory modify the OAuthServer.config. Notice the location of the file to edit. It is important to do this in the transforms folder as shown in the screenshot below:

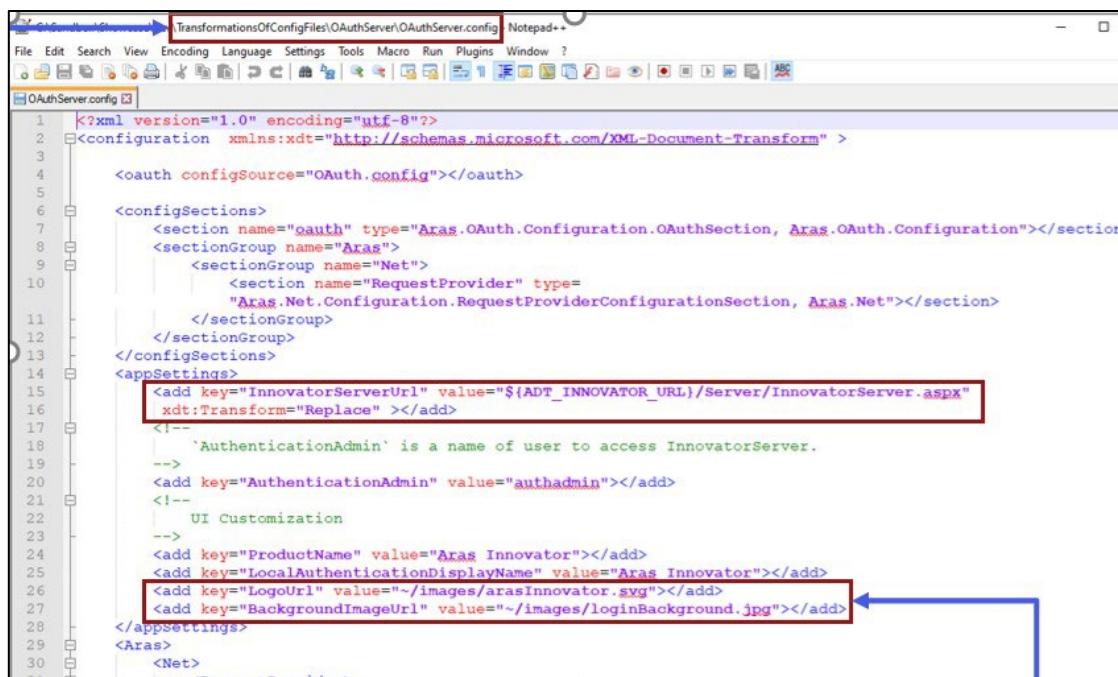

Note: It is best to use the OAuth installation path directly as it may be installed differently. ADT_OAUTH_INSTALLATIONPATH.

```

1 <?xml version="1.0" encoding="utf-8"?>
2 <configuration xmlns:xdt="http://schemas.microsoft.com/XMl-Document-Transform" >
3
4   <oauth configSource="OAuth.config"></oauth>
5
6   <configSections>
7     <section name="oauth" type="Aras.OAuth.Configuration.OAuthSection, Aras.OAuth.Configuration"></section>
8     <sectionGroup name="Aras">
9       <sectionGroup name="Net">
10        <section name="RequestProvider" type="
11          "Aras.Net.Configuration.RequestProviderConfigurationSection, Aras.Net"></section>
12        </sectionGroup>
13      </sectionGroup>
14    </configSections>
15    <appSettings>
16      <add key="InnovatorServerUrl" value="{ADT_INNOVATOR_URL}/Server/InnovatorServer.aspx
17      xdt:Transform="Replace" ></add>
18      <!--
19      -->
20      <!-- "AuthenticationAdmin" is a name of user to access InnovatorServer.
21      -->
22      <add key="AuthenticationAdmin" value="authadmin"></add>
23      <!--
24      -->
25      <!-- UI Customization
26      -->
27      <add key="ProductName" value="Aras Innovator"></add>
28      <add key="LoginAuthenticationDisplayName" value="Aras Innovator"></add>
29      <add key="LoginUrl" value="/Images/ArasInnovator.aspx"></add>
30      <add key="BackgroundImageUrl" value="/Images/LoginBackground.jpg"></add>
31    </appSettings>
32    <Aras>
33      <Net>
34        <RequestProvider>

```

Legend:

```

<add key="LoginUrl" value="{ADT_INNOVATOR_INSTALLATIONPATH}/OAuthServer/WWWroot/Images/customerLogo.svg" xdt:Transform="Replace" ></add>
<add key="BackgroundImageUrl" value="{ADT_OAUTH_INSTALLATIONPATH}/Images/customerLoginBackground.jpg" xdt:Transform="Replace" ></add>

```

4. Stage the changes before running the build scripts.
5. Execute **./BuildAndDeploy.ps1** to rebuild Innovator.
6. Notice the changes to the login screen.

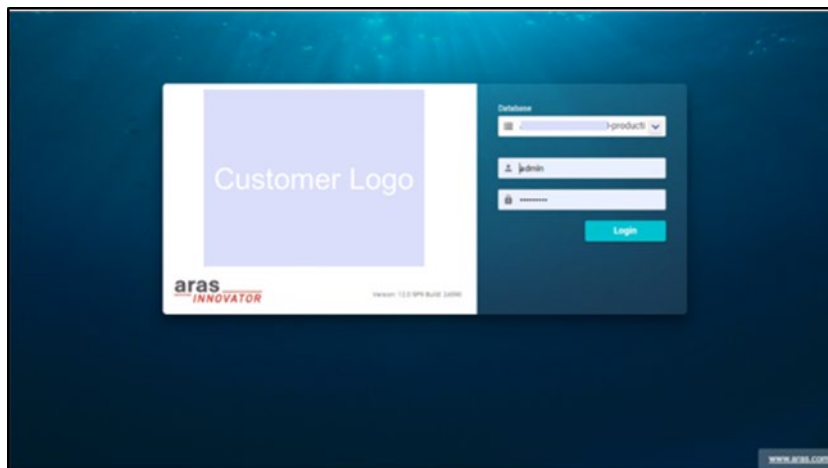

13.2 Change Banner

The following steps outline the process to update the banner logo:

1. First, start by navigating to the existing image.
2. Login into Aras Innovator instance.
3. From the **Table of Contents**, expand **Administration, Configuration** and select **Client Presentation**.

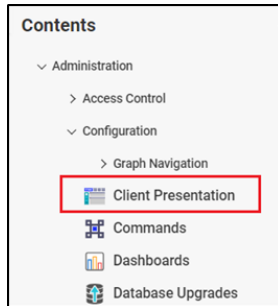

4. From Client Presentation Table of Contents, click Search Client Presentation.

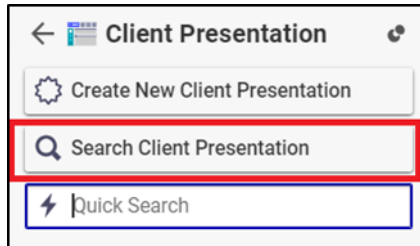

5. On **Client Presentation** form, click **Search** and click **Global**.

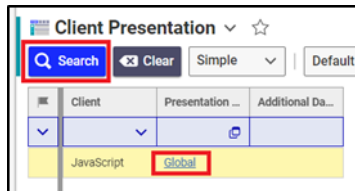

6. In **CommandBarSection** tab, select row with **Main Window Header** label.

Classification	Name	Builder Meth...	Label	Description	Additional Da...	Location [-]	sort_order	For Identity [-]	For Classifica...
Data Model	com.aras.inno...		entendchMenuUpViewerToolBar	{ 'buttonstyle...	entendchBar...		5376	World	
Method	com.aras.inno...	CuMainWin...			PopuMenu...		5760	World	
Method	com.aras.inno...	CuMainWin...			PopuMenu...		6144	World	
Method	com.aras.inno...	CuMainWin...			PopuMenu...		6528	World	
Data Model	com.aras.inno...		Default TGV Toolbar		TGV_Toolbar		6656	World	
Data Model	com.aras.inno...		TGV Context Menu Default		TGV_Context...		6784	World	
Data Model	com.aras.inno...		Main Window Header		MainWindow...		6972	World	
Data Model	com.aras.inno...		Effectivity Expression Item Gric T...		eff_expressi...		6912	World	
Data Model	com.aras.inno...				MainWindow...		7040	World	
Method	com.aras.inno...	cu_default...			IGC		7168	World	
Data Model	ItemView.Item...		Item View Default Command Bar		ItemView.Be...		7296	World	

7. Select **com.aras.innovator.cui_default.mwh_header_logo**.

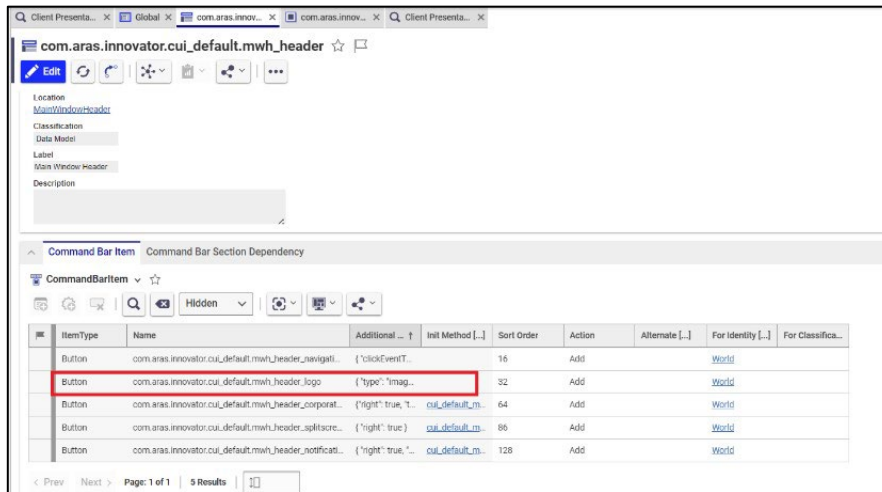

8. Notice the existing image. The height is very important for adjusting the customer's logo to fit while maintaining conformity with the customer's branding guidelines.

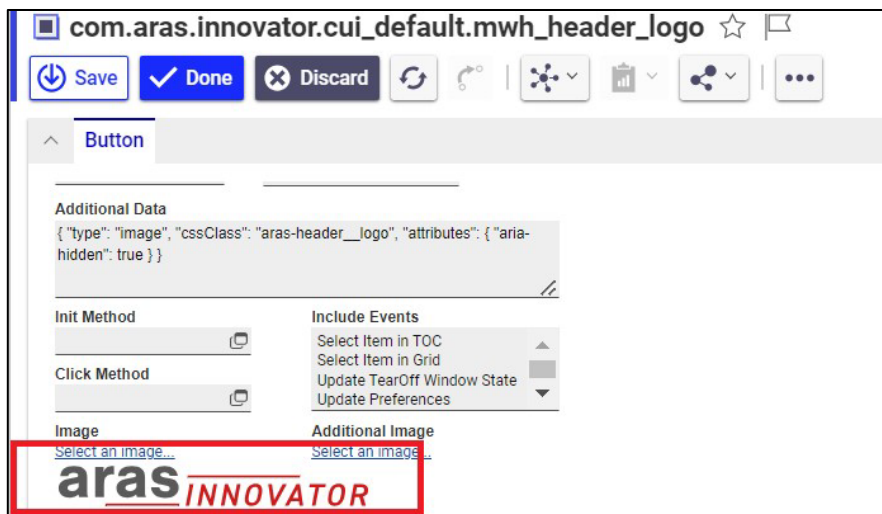

9. On the local machine, add the required Customer Logo in the following directory:
C:\{working directory}\Instances\dev\OAuthServer\wwwroot\images
The image should be in SVG format.

10. Navigate to the following folder: C:\{Working Directory}\AML-packages\com\aras\innovator\cui_default\CommandBarButton

11. Open **com.aras.innovator.cui_default.mwh_header_logo** file.

12. In the **com.aras.innovator.cui_default.mwh_header_logo** file, do the following:

- Change the action attribute from “add” to “edit”.
- Add the CustomerLogo.svg in the Image tag. Ensure that the path is correct.

```
<AML>
<Item type="CommandBarButton" id="83E579F8F084B508927F070D099091E" action="add">
  <additional_data> { "type": "image", "cssClass": "aras-header_logo", "attributes": { "aria-hidden": true } }</additional_data>
  <image>../images/CustomerLogo.svg</image>
  <name>com.aras.innovator.cui_default.mwh_header_logo</name>
</Item>
</AML>
```

13. Execute **./BuildAndDeploy.ps1** to rebuild Innovator and notice the changes to the Banner.

Appendix I: Local Development Environment Setup

For a contributor to make changes and test them locally, the contributor needs an environment that supports the various elements of a deployment such a development database server.

This section outlines the essential requirements for setting up a local development environment, essential for making changes. It covers the necessary software, tools, and configurations needed to create a productive and efficient development environment. By following the points below, users can ensure that their local development setup meets the prerequisites for seamless software development and testing.

The preparation of this environment is primarily automated; however, the following tools must be present before running the scripts:

- Windows PowerShell (minimum version is 5.1) Please use the latest version.
- Chocolatey - <https://chocolatey.org/install> (version 0.11.0)
- choco install gitextensions <https://community.chocolatey.org/packages/gitextensions>

Installing Windows Powershell

If Windows PowerShell is not already installed on the system, ensure to set up the most recent version.

To install, please visit: <https://learn.microsoft.com/en-us/powershell/scripting/install/installing-powershell-on-windows?view=powershell-7.3>.

Installing Chocolatey using Windows PowerShell

The following steps outline the process of installing the Chocolatey tool using Windows PowerShell:

1. Open Windows PowerShell and run as Administrator.

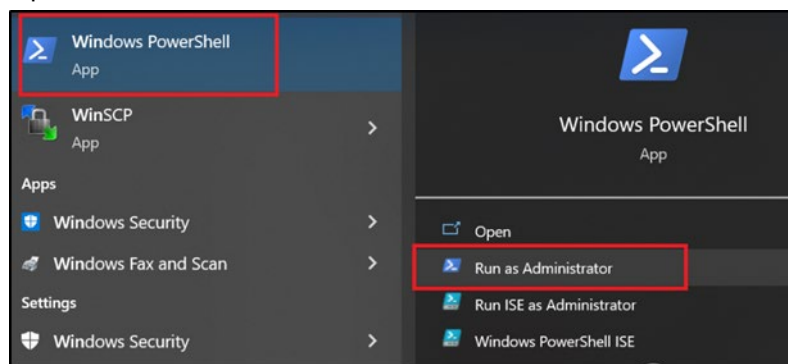

With PowerShell, please ensure that Get-ExecutionPolicy is not Restricted. We suggest using Bypass to bypass the policy to get things installed or AllSigned for quite a bit more security.

Run Get-ExecutionPolicy. If it returns Restricted, then run Set-ExecutionPolicy AllSigned or Set-ExecutionPolicy Bypass -Scope Process.

- Copy the following command and paste into PowerShell:
`Set-ExecutionPolicy Bypass -Scope Process -Force; [System.Net.ServicePointManager]::SecurityProtocol = [System.Net.ServicePointManager]::SecurityProtocol -bor 3072; iex ((New-Object System.Net.WebClient).DownloadString('https://community.chocolatey.org/install.ps1'))`

```
Administrator: Windows PowerShell
Copyright (C) Microsoft Corporation. All rights reserved.

Try the new cross-platform PowerShell https://aka.ms/pscore6

PS C:\windows\system32> Set-ExecutionPolicy Bypass -Scope Process -Force; [System.Net
.ServicePointManager]::SecurityProtocol = [System.Net.ServicePointManager]::SecurityP
rotocol -bor 3072; iex ((New-Object System.Net.WebClient).DownloadString('https://com
munity.chocolatey.org/install.ps1'))
```

- Wait a few seconds for the command to complete.
- For more information, please visit <https://chocolatey.org/install>.

Installing Git

The recommended minimum Git version is 2.23.0. Please use the latest version of Git. Install Git using any 1 method below:

- Install Git from the official site: <https://git-scm.com/downloads>.
- Using Chocolatey package manager. In PowerShell type the following command: `Choco upgrade -y git`.

```
PS C:\windows\system32> choco upgrade -y git
Chocolatey v1.3.1
Upgrading the following packages:
git
By upgrading, you accept licenses for the packages.
git is not installed. Installing...
Progress: Downloading git.install 2.40.0... 100%
Progress: Downloading git.install 2.40.0... 100%
Progress: Downloading chocolatey-core.extension 1.4.0... 100%
Progress: Downloading chocolatey-core.extension 1.4.0... 100%
Progress: Downloading chocolatey-compatibility.extension 1.0.0... 100%
Progress: Downloading chocolatey-compatibility.extension 1.0.0... 100%
Progress: Downloading git 2.40.0... 100%
Progress: Downloading git 2.40.0... 100%

chocolatey-compatibility.extension v1.0.0 [Approved]
chocolatey-compatibility.extension package files upgrade completed. Performing other installation steps.
Installed/updated chocolatey-compatibility extensions.
The upgrade of chocolatey-compatibility.extension was successful.
Software installed to 'C:\ProgramData\chocolatey\extensions\chocolatey-compatibility'

chocolatey-core.extension v1.4.0 [Approved]
chocolatey-core.extension package files upgrade completed. Performing other installation steps.
Installed/updated chocolatey-core extensions.
The upgrade of chocolatey-core.extension was successful.
Software installed to 'C:\ProgramData\chocolatey\extensions\chocolatey-core'

git.install v2.40.0 [Approved]
git.install package files upgrade completed. Performing other installation steps.
Using Git LFS
Installing 64-bit git.install...
git.install has been installed.
git.install installed to 'C:\Program Files\Git'
git.install can be automatically uninstalled.
Environment Vars (like PATH) have changed. Close/reopen your shell to
see the changes (or in powershell/cmd.exe just type 'refreshenv').
The upgrade of git.install was successful.
Software installed to 'C:\Program Files\Git\'

git v2.40.0 [Approved]
git package files upgrade completed. Performing other installation steps.
The upgrade of git was successful.
Software installed to 'C:\ProgramData\chocolatey\lib\git'

Chocolatey upgraded 4/4 packages.
See the log for details (C:\ProgramData\chocolatey\logs\chocolatey.log).
PS C:\windows\system32>
```

Installing Azure CLI

To install Azure CLI, please visit <https://learn.microsoft.com/en-us/cli/azure/install-azure-cli>.

To install the Azure DevOps extension for Azure CLI, please visit <https://learn.microsoft.com/en-us/azure/devops/cli/?view=azure-devops>.

Required Specifications

The following specifications are required for Local Development Environments (LDE):

- MSSQL Server 2019 or 2022
- The contained database authentication option must be enabled as shown:
 - `sp_configure 'contained database authentication', 1;`
 - `GO`
 - `RECONFIGURE;`
 - `GO`
- SSMS SQL Server Management Studio 2019 or 2022
- The contained database authentication option can also be enabled in SSMS SQL Server Management Studio.
- MS IIS Server
- File diff/merge tool (e.g., Kdiff3)
- Git 2.23 (Minimum Version). Please use the latest version.
- Git Extensions
- Visual Studio Community (Professional) Edition or above 2019 and 2022
- Visual Studio Code 1.77 or later

Appendix II: Standard Solution Packaging Tools

The Package Import Export Utilities are provided with every Aras Innovator release.

Export.exe

This tool is part of the Package Import Export Utilities. The Export tool allows users to select package elements to export to the file system as XML. These package elements can be exported individually, as part of a Package Group, or as part of a Package Definition.

Import.exe

This tool is part of the Package Import Export Utilities. The Import tool allows users to select predefined manifest files and import the corresponding package AMLs into a database. In a CI/CD environment, users do not have to do any imports manually. These will be automated steps triggered by the relevant CI/CD automations.

Consoleupgrade.exe

This tool is part of the Package Import Export Utilities. The Console Upgrade Tool is a command line version of both the Export Tool and Import Tool described above. The command line parameters can be found by typing `/?` as the command line parameter. In a CI/CD process this tool is part of the deployment automation and does not have to be used manually.

Appendix III: Adding Applications to a Project

When a project starts, it may wish to use several applications and potentially language packages. This section explains how to add an application in the project repository. For reference, the following steps showcase the instructions to install Simulation Management (SM) application. The steps might differ depending on the application user chooses to integrate with Aras Innovator.

The following steps outlines the process of adding SM application:

1. Determine the required version for application installation by comparing the version of the current Aras Innovator with the specified name of the Application to be installed in the [Support Matrix](#).

End of Life	APPLICATIONS												INTEGRATIONS			
	Product Engineering	Program Management	Requirements Engineering	Systems Architecture	Simulation Management	Component Engineering	Technical Communication	Quality Management System	Process Quality Review	Manufacturing Process Planning	Digital Twin Core	Office Connector	Enterprise Search	3D Visualization	Process Engine	
Release 14 (Build 14.0.0.33343)	Release 14 (14.0.1)	Release 14 (14.0.1)	Release 14 (14.0.1)	Release 14 (14.0.1)	Release 14 (14.0.1)	Release 14 (14.0.1)	Release 14 (14.0.1)	Release 14 (14.0.1)	Release 14 (14.0.1)	Release 14 (14.0.1)	Release 14 (14.0.1)	Release 14 (14.0.1)	Release 14 (14.0.1)	Release 14 (14.0.1)	Release 15 (14.0.1)	
Release 15 (Build 14.0.1.33397)	Release 14 (14.0.1)	Release 14 (14.0.1)	Release 14 (14.0.1)	Release 14 (14.0.1)	Release 14 (14.0.1)	Release 14 (14.0.1)	Release 14 (14.0.1)	Release 14 (14.0.1)	Release 14 (14.0.1)	Release 14 (14.0.1)	Release 14 (14.0.1)	Release 14 (14.0.1)	Release 20 (14.0.2)	Release 19 (14.0.2)	Release 15 (14.0.1)	
Release 16 (Build 14.0.2.33805)	Release 14 (14.0.1)	Release 14 (14.0.1)	Release 14 (14.0.1)	Release 14 (14.0.1)	Release 14 (14.0.1)	Release 14 (14.0.1)	Release 14 (14.0.1)	Release 14 (14.0.1)	Release 14 (14.0.1)	Release 14 (14.0.1)	Release 14 (14.0.1)	Release 14 (14.0.1)	Release 20 (14.0.2)	Release 19 (14.0.2)	Release 15 (14.0.1)	
Release 17 (Build 14.0.3.34066)	Release 14 (14.0.1)	Release 14 (14.0.1)	Release 14 (14.0.1)	Release 14 (14.0.1)	Release 14 (14.0.1)	Release 14 (14.0.1)	Release 14 (14.0.1)	Release 14 (14.0.1)	Release 14 (14.0.1)	Release 14 (14.0.1)	Release 14 (14.0.1)	Release 14 (14.0.1)	Release 20 (14.0.2)	Release 19 (14.0.2)	Release 15 (14.0.1)	
Release 18 (Build 14.0.4.34465)	Release 14 (14.0.1)	Release 14 (14.0.1)	Release 14 (14.0.1)	Release 14 (14.0.1)	Release 14 (14.0.1)	Release 14 (14.0.1)	Release 14 (14.0.1)	Release 14 (14.0.1)	Release 14 (14.0.1)	Release 14 (14.0.1)	Release 14 (14.0.1)	Release 14 (14.0.1)	Release 20 (14.0.2)	Release 19 (14.0.2)	Release 15 (14.0.1)	
Release 19 (Build 14.0.4.34717)	Release 14 (14.0.1)	Release 14 (14.0.1)	Release 14 (14.0.1)	Release 14 (14.0.1)	Release 14 (14.0.1)	Release 14 (14.0.1)	Release 14 (14.0.1)	Release 14 (14.0.1)	Release 14 (14.0.1)	Release 19 (14.0.2)	Release 19 (14.0.2)	Release 14 (14.0.1)	Release 20 (14.0.2)	Release 19 (14.0.2)	Release 16 (14.0.1)	
Release 20 (Build 14.0.4.34717)	Release 14 (14.0.1)	Release 14 (14.0.1)	Release 14 (14.0.1)	Release 14 (14.0.1)	Release 14 (14.0.1)	Release 14 (14.0.1)	Release 14 (14.0.1)	Release 14 (14.0.1)	Release 14 (14.0.1)	Release 19 (14.0.2)	Release 20 (14.0.2)	Release 20 (14.0.2)	Release 20 (14.0.2)	Release 19 (14.0.2)	Release 16 (14.0.1)	

Certified - QA and Acceptance Testing Completed
Supported - Not Certified - Aras Provides Full Support
End of Life - This product has reached end of life

2. Download the Simulation Management CD image from the Aras FTP site and unzip the file on the local computer.
3. Copy the Aras Innovator folder to the repository overwriting the existing \Innovator folder and all its contents.
4. Copy the content from the Import folder and paste it into AML Packages folder.
5. Make sure to update the Import Manifest file. The following line is present in the **Import.mf** file:
<package name="com.aras.innovator.solution.SM" path="SM\Import" />

```
<?xml version="1.0" encoding="utf-8"?>
<imports>
  <package name="com.aras.innovator.solution.SM" path="SM\Import" />
</imports>
```

6. Commit the changes with an appropriate message.
7. Run **.\BuildAndDeploy.ps1** to ensure that updates build successfully.
8. After successful execution of **.\BuildAndDeploy.ps1**, commit and push the changes.
9. Once changes are pushed, create Pull Request (PR) and merge the changes. Refer to section 4.10 Creating a Pull Request to learn about creating a PR.
10. Continuous Integration pipeline will execute successfully after merge.
11. To generate a new baseline, create a tag on the latest commit. Refer to section 7.2 Generating New Baseline to learn about generating a new baseline.



Appendix IV: Using a Shared Repository and Merging Conflicts

Use Shared Repository

Multiple developers use a central (also called remote) repository which allows each authorized developer to push and fetch changes from a single source. Although each developer maintains a local copy of the repository on their machine, the remote repository collects the changes from everyone on the team. Each developer is responsible for updating or fetching changes from the remote repository on a regular basis.

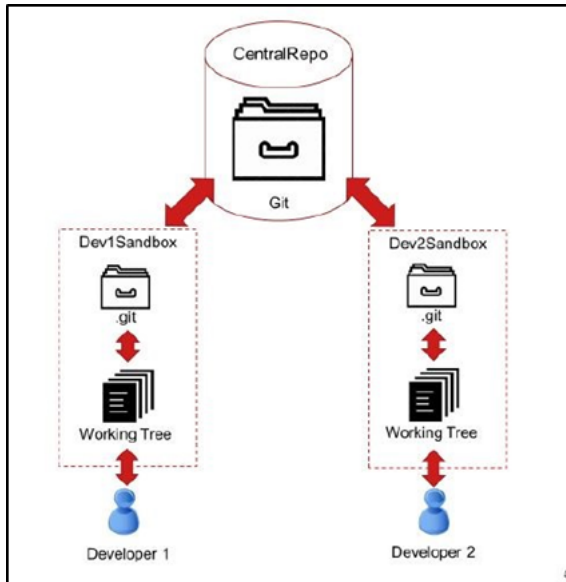

Connect to Shared Repository

Adding a remote reference allows developers to establish a connection between their local repository and a remote repository. It enables developers to push their changes to the remote repository, fetch updates made by others, and synchronize their work with the rest of the team.

Push Changes to Shared Repository

Pushing changes to a remote repository allows the developer to send the local commits and updates to the remote repository, making them accessible to others working on the project.

Fetch Changes from Shared Repository

Fetching changes from the shared repository ensures that the developers have the most recent code updates, allowing them to incorporate the changes into the local branch and maintain a synchronized codebase.

Managing File Conflicts

A merge conflict occurs when two or more developers make conflicting changes to the same part of a file. For example, if Developer 1 modifies a function while Developer 2 modifies the same function, the version control system may not be able to automatically determine which changes should take precedence.

Resolving Merged Conflicts

When working with Git, it is possible to encounter conflicts when merging two branches. This occurs when Git is unable to automatically merge changes made to the same lines of code in both branches.

The following steps outline the process to resolve merge conflicts:

1. Open the file(s) that have conflicts.
2. Look for the conflict markers in the file(s), which looks like below screenshot:

```
CSS

<<<<<<< HEAD
code from the current branch
=====
code from the branch being merged
>>>>>> branch-name
```

3. Edit the code to reflect the changes to be kept.
4. Remove the conflict markers from the file(s).
5. Save the changes to the file(s).
6. Add the modified file(s) to the staging area.
7. Commit the changes.
8. Push the changes to the remote repository.

If using a Merge tool like VS Code or SourceTree, it should have a graphical interface to help resolve conflicts more easily. Launch the tool and follow its instructions to resolve conflicts.

It's important to note that resolving merge conflicts can be a complex and time-consuming process, especially if there are many conflicts to resolve. It's always a good idea to carefully review and test changes after resolving conflicts to ensure they work as intended.

Sharing Changes with the Remote Repository

Once the changes are made to the local repository and resolved any Merge conflicts, developers need to share those changes with the remote repository. Here are few Developer responsibilities:

- **Commit Changes:** It is essential to commit changes locally. Make frequent well documented commits.
- **Fetch the Latest Changes:** It is good practice to fetch the latest changes from the remote repository. This ensures that the user has the most up-to-date version of the codebase and reduces the chances of conflicts.
- **Rebase:** Use Rebase to update local repository with remote repository changes.
- **Push Changes:** Push local repository changes to the remote repository frequently.
- **Verify Changes:** After pushing the changes, it is essential to verify that they have been successfully shared with the remote repository.

Using Stash

Stash allows developers to store the modifications, including both staged and un-staged changes, in a safe place so that they can switch to a clean working directory without losing their work. It acts as a temporary storage for their changes, enabling them to move between tasks or branches seamlessly. Stashing is particularly useful when developers are not yet ready to commit their changes or when they want to work on a different task without the interference of their current modifications.

The following points will explain the process of using stash effectively:

1. **Stashing Changes:** A common use case for stashing changes is when users make changes to the working directory that are not yet committed but need to fetch changes from another developer in the remote repository.
2. **Viewing the Stash:** User can view the contents of the stash at any time by using the `git stash list` command. Users can also view the stash graphically by reviewing the Revision Graph diagram.
3. **Applying the Stash Changes:** When ready, users can restore the stash into the current staged snapshot and then commit the changes including the stashed changes.

Appendix V: Transformations

This section illustrates the transformation to add converters available to the project team. The platform includes the template shown below. The project team must complete the changes required in an idempotent manner.

The following template is provided:

```
<?xml version="1.0" encoding="utf-8"?>
<configuration>
  <configSections>
    <!-- Common converter service configuration -->
    <section name="ConversionServer"
type="Aras.ConversionFramework.ConversionServer.Configuration.ConversionSe
rverConfigurationSection, Conversion.Base" />
    <sectionGroup name="ConverterSettings">
      <!-- Place here class configuration section definitions for
converters -->
      <section name="ArasCadConverter"
type="Aras.ConversionFramework.Converter.Hoops.Configuration.HoopsConverte
rConfiguration"/>
    </sectionGroup>
  </configSections>
  <ConversionServer>
    <InnovatorServer url="" />
    <Converters>
      <Converter name="Aras CAD to PDF Converter"
type="Aras.ConversionFramework.Converter.Hoops.HoopsConverter, ArasCadConve
rter"/>
    </Converters>
  </ConversionServer>
  <ConverterSettings>
    <!-- Place here configuration sections for converters -->
    <ArasCadConverter>
      <Application
converterPath="${Path.To.Hoops.Converter.Dir}\bin\hoops_converter.exe"/>
      <Command arguments="--input_pdf_template_file
'${Path.To.Hoops.Converter.Dir}\templates\Blank_Template_L.pdf' --
output_pdf '%filepath%\%filename%.pdf' --output_png
'%filepath%\%filename%.png' --output_png_resolution '150x150' --output_hwf
'%filepath%\%filename%.hwf' --output_prc '%filepath%\%filename%.prc' --
camera_default --output_logfile '%filepath%\%filename%'"/>
    </ArasCadConverter>
  </ConverterSettings> </configuration>
```

To activate conversion per the requirements and entitlements of a project, the project team must provide information in the transformation file.

Below is an illustration of the desired state.

```
<?xml version="1.0"?>
<configuration xmlns:xdt="http://schemas.microsoft.com/XML-Document-Transform">
  <!-- Sections -->
  <configSections xdt:Transform="Replace" xdt:Locator="XPath(/configuration/configSections)">
    <!-- Common converter service configuration -->
    <sectionGroup name="ConversionServer" type="Aras.ConversionFramework.ConversionServer.Configuration.ConversionServerConfigurationSection, conversion.Base" />
    <sectionGroup name="ConverterSettings">
      <section name="ArasCadConverter" type="Aras.ConversionFramework.Converter.Hoops.Configuration.HoopsConverterConfiguration, ArasCadConverter" />
      <section name="ArasCadConverterPrc" type="Aras.ConversionFramework.Converter.Hoops.Configuration.HoopsConverterConfiguration, ArasCadConverter" />
      <section name="PdfPublishingConverter" type="Aras.Publishing.Configuration.PdfConverterConfig, Aras.TDF.PublishingConverter" />
    </sectionGroup>
  </configSections>
  <conversionServer xdt:Transform="Replace" xdt:Locator="XPath(/configuration/conversionServer)">
    <InnovatorServer url="{ADT_INNOVATOR_URL}/Server/InnovatorServer.aspx" xdt:Transform="Replace" />
    <Converters>
      <Converter name="cmf_ExcelPublishingConverter" type="Aras.Cmf.Publishing.Excel.ExcelExportConverter, Aras.Cmf.Publishing" />
      <Converter name="cmf_XpsPrintingConverter" type="Aras.Cmf.Publishing.Xps.XpsPrintingConverter, Aras.Cmf.Publishing" />
      <Converter name="Aras CAD To PDF Converter" type="Aras.ConversionFramework.Converter.Hoops.HoopsConverter, ArasCadConverter" />
      <Converter name="Aras PRC to SCS Converter" type="Aras.ConversionFramework.Converter.Hoops.HoopsConverterPrc, ArasCadConverter" />
      <Converter name="tp_XmlPublishingConverter" type="Aras.Publishing.XmlPublishingConverter, Aras.TDF.PublishingConverter" />
      <Converter name="tp_PdfPublishingConverter" type="Aras.Publishing.PdfPublishingConverter, Aras.TDF.PublishingConverter" />
      <Converter name="tp_HtmlPublishingConverter" type="Aras.Publishing.HtmlPublishingConverter, Aras.TDF.PublishingConverter" />
      <Converter name="PDF.Watermarking" type="Aras.PDF.Watermarking.PdfWatermarkConverter, Aras.PDF.Watermarking" />
    </Converters>
  </conversionServer>
  <ConverterSettings xdt:Transform="Replace" xdt:Locator="XPath(/configuration/ConverterSettings)">
    <!-- Place here configuration sections for converters -->
    <ArasCadConverter>
      <Application converterPath=".\\HOOPS Converter\\bin\\converter.exe" />
      <Command arguments="--sc_compute_bounding_boxes 'All' --input_pdf_template_file '.\\HOOPS Converter\\templates\\blank_Template_L.pdf' --output_pdf '%filepath%\\filename%.pdf'" />
      <Output>
        <UploadToVault>
          <File extension="prc" argsMarkers="--output prc" />
          <File extension="scs" argsMarkers="--output_scs" />
          <File extension="pdf" argsMarkers="--output_pdf" />
          <File extension="png" argsMarkers="--output_png" />
          <File extension="stl" argsMarkers="--output_stl" />
          <File extension="xml" argsMarkers="--output_xml_assemblytree" />
        </UploadToVault>
      </Output>
      <AssemblyCommand dynamicEnabled="True" arguments="--sc_compute_bounding_boxes 'All' --input_pdf_template_file '.\\HOOPS Converter\\templates\\blank_Template_L.pdf' --output_p" />
    </ArasCadConverter>
    <ArasCadConverterPrc>
      <Application converterPath=".\\HOOPS Converter\\bin\\converter.exe" />
      <Command arguments="--output_scs '%filepath%\\filename%.scs' --output_xml_assemblytree '%filepath%\\filename%.xml' --output_logfile '%filepath%\\filename%.log'" />
      <Output>
        <UploadToVault>
          <File extension="prc" argsMarkers="--output prc" />
          <File extension="scs" argsMarkers="--output_scs" />
          <File extension="pdf" argsMarkers="--output_pdf" />
          <File extension="png" argsMarkers="--output_png" />
          <File extension="stl" argsMarkers="--output_stl" />
          <File extension="xml" argsMarkers="--output_xml_assemblytree" />
        </UploadToVault>
      </Output>
      <AssemblyCommand dynamicEnabled="True" arguments="--sc_compute_bounding_boxes 'All' --input_pdf_template_file '.\\HOOPS Converter\\templates\\blank_Template_L.pdf' --output_p" />
    </ArasCadConverterPrc>
    <PdfPublishingConverter>
      <ConversionTool path="{ADT_CONVERSION_INSTALLATIONPATH}\\Prince\\bin\\prince.exe" />
    </PdfPublishingConverter>
  </ConverterSettings>
</configuration>
```

For more specific information about a specific converter, please refer to the relevant product documentation. This documentation will provide the essential specifications that need to be added.



3. For "Section Group," add missing Converter elements to the "Converters" element.

```
<Converters>
  <Converter name="cmf_ExcelPublishingConverter" type="Aras.Cmf.Publishing.Excel.ExcelExportConverter, Aras.Cmf.Publishing" />
  <Converter name="cmf_XpsPrintingConverter" type="Aras.Cmf.Publishing.Xps.XpsPrintingConverter, Aras.Cmf.Publishing" />
  <Converter name="Aras CAD to PDF Converter" type="Aras.ConversionFramework.Converter.Hoops.HoopsConverter, ArasCadConverter" />
  <Converter name="Aras PRC to SCS Converter" type="Aras.ConversionFramework.Converter.Hoops.HoopsConverterPrc, ArasCadConverter" />
  <Converter name="tp_XmlPublishingConverter" type="Aras.Publishing.XmlPublishingConverter, Aras.TDF.PublishingConverter" />
  <Converter name="tp_PdfPublishingConverter" type="Aras.Publishing.PdfPublishingConverter, Aras.TDF.PublishingConverter" />
  <Converter name="tp_HtmlPublishingConverter" type="Aras.Publishing.HtmlPublishingConverter, Aras.TDF.PublishingConverter" />
  <Converter name="PDF.Watermarking" type="Aras.PDF.Watermarking.PdfWatermarkConverter, Aras.PDF.Watermarking" />
</Converters>
```

4. Add converters if missing for the "ConverterSettings" element. Notice that these elements have child elements.

```
<ConverterSettings xdt:Transform="Replace" xdt:Locator="XPath(/configuration/ConverterSettings)">
  <!-- Place here configuration sections for converters -->
  <ArasCadConverter>
    <Application converterPath=".\HOOPS Converter\bin\converter.exe" />
    <Command arguments="--sc_compute_bounding_boxes 'All' --input_pdf_template_file '.\HOOPS Converter\templates\Blank_Template_1.pdf' --output_pdf '%filepath%\%filename%.pdf' />
    <Output>
      <uploadToVault>
        <File extension="prc" argsMarkers="--output_prc" />
        <File extension="scs" argsMarkers="--output_scs" />
        <File extension="pdf" argsMarkers="--output_pdf" />
        <File extension="png" argsMarkers="--output_png" />
        <File extension="stl" argsMarkers="--output_stl" />
        <File extension="xml" argsMarkers="--output_xml_assemblytree" />
      </uploadToVault>
    </Output>
    <AssemblyCommand dynamicEnabled="True" arguments="--sc_compute_bounding_boxes 'All' --input_pdf_template_file '.\HOOPS Converter\templates\Blank_Template_1.pdf' --output_prc '%filepath%\%filename%.prc' />
  </ArasCadConverter>
  <ArasCadConverterPrc>
    <Application converterPath=".\HOOPS Converter\bin\converter.exe" />
    <Command arguments="--output_scs '%filepath%\%filename%.scs' --output_xml_assemblytree '%filepath%\%filename%.xml' --output_logfile '%filepath%\%filename%.log' />
    <Output>
      <uploadToVault>
        <File extension="prc" argsMarkers="--output_prc" />
        <File extension="scs" argsMarkers="--output_scs" />
        <File extension="pdf" argsMarkers="--output_pdf" />
        <File extension="png" argsMarkers="--output_png" />
        <File extension="stl" argsMarkers="--output_stl" />
        <File extension="xml" argsMarkers="--output_xml_assemblytree" />
      </uploadToVault>
    </Output>
  </ArasCadConverterPrc>
  <PdfPublishingConverter>
    <ConversionTool path="{ADT_CONVERTION_INSTALLATIONPATH}\Prince\bin\prince.exe" />
  </PdfPublishingConverter>
</ConverterSettings>
```

Appendix VI: Vault Replication

This section illustrates the process of enabling vault replication for the Aras Innovator instance. Enabling the vault replication for the Aras Innovator instance requires two following steps:

1. Creating a transformation file
2. Running the pipelines

Create Transformation File

The following steps outline the process of creating transformation file:

1. Create a transformation configuration file in the /TransformationsOfConfigFiles/AgentService/ folder of the Work.git repository and name it as replication.config.
2. Add the following content in the file:

```
<replication xmlns:xdt= http://schemas.microsoft.com/XML-Document-Transform status="enabled" xdt:Transform="SetAttributes(status)"></replication>
```
3. Commit the changes.

Run Pipelines

The following pipelines can process the Aras Innovator deployments with vault replication:

- continuous-integration
- deploy-innovator
- delete-innovator
- apply-fix

The following steps outline the process of configuring a pipeline to enable vault replication:

1. To configure the pipeline to deploy Aras Innovator **with** vault replication, set the cluster_index pipeline variable to '00'.
2. To configure the pipeline to deploy Aras Innovator **without** vault replication, set the cluster_index pipeline variable to '01'.

A value of 00 indicates that the pipeline deploys the necessary components needed to enable vault replication on all clusters.

A value of 01 indicates that the pipeline deploys only the primary Aras Innovator instance without vault replication.

Please refer to the Aras Innovator – Configuring Vault Replication document to know the steps on configuring the replication rules.